

**TONGAN KINSHIP TERMINOLOGY:  
INSIGHTS FROM AN ALGEBRAIC ANALYSIS**

**GIOVANNI BENNARDO**  
DEPARTMENT OF ANTHROPOLOGY  
NORTHERN ILLINOIS UNIVERSITY  
[bennardo@niu.edu](mailto:bennardo@niu.edu)

AND

**DWIGHT READ**  
DEPARTMENT OF ANTHROPOLOGY  
UNIVERSITY OF CALIFORNIA LOS ANGELES  
[dread@anthro.ucla.edu](mailto:dread@anthro.ucla.edu)

**COPYRIGHT 2005  
ALL RIGHTS RESERVED BY AUTHORS**

**MATHEMATICAL ANTHROPOLOGY AND CULTURAL THEORY:  
AN INTERNATIONAL JOURNAL  
ISSN 1544-5879**

**TONGAN KINSHIP TERMINOLOGY:  
INSIGHTS FROM AN ALGEBRAIC ANALYSIS**

**GIOVANNI BENNARDO**  
DEPARTMENT OF ANTHROPOLOGY  
NORTHERN ILLINOIS UNIVERSITY

**DWIGHT READ**  
DEPARTMENT OF ANTHROPOLOGY  
UNIVERSITY OF CALIFORNIA LOS ANGELES

*Abstract We present an algebraic account of the Tongan kinship terminology (TKT) that provides an insightful journey into the fabric of Tongan society. We begin with the ethnographic account of a social event. The account provides us with the activities of that day and the centrality of kin relations in the event, but it does not inform us of the underlying logic for the conceptual system of kin relations that the participants bring with them. Rather, it is a slice in time of an ongoing dynamic process that links behavior with kin and kin with behavior. To fully understand this interplay we need to account for the structure underlying their conceptual system of kin relations that is being activated during the event. Thus, we introduce a formal, algebraically based account of TKT as a way to make evident what is otherwise “hidden” logic. This account brings to the fore the underlying logic of TKT and the features of TKT that are a consequence of that logic. This also allows us to distinguish between structural features of the kinship system that arise from the logic of TKT versus features that must have arisen through the intervention of, or intersection with, other cultural conceptual systems. Finally, we revisit the ethnographic account and we consider those aspects whose explication must lie in other cultural interventions, thus linking the kinship conceptual system to other conceptual domains such as ranking and inheritance.*

**0. Introduction**

Tongan social events such as first birthday, marriage and death are deeply intertwined with one's world of kin. The persons central to these events are kin of various kinds and the events serve to define and redefine core kin relations and relations between kin such as the *fahu* relationship. We begin the paper with the ethnographic account of a first birthday attended to by the first author. The events of that day highlight the interplay between the formal properties of kinship expressed through a kinship terminology and how the meaning of those kin relations are played out and constructed in the context of a family

celebrating the first birthday of a daughter. The ethnographic account provides us with the activities of that day and the centrality of kin relations in those events, but it does not inform us of the conceptual system that the participants bring with them as culture bearers to this event. Rather, it is a slice in time of an ongoing dynamic process that links behavior with a conceptual system of kin relations and a conceptual system of kin relations with behavior. The events of the day are a co-production of the dynamic and the static; of kinship as it is lived and kinship as it is conceptualized. To understand this interplay we need not only the ethnographic account but also an account of the underlying conceptual system that is being activated during this event.

We argue that the genealogical<sup>1</sup> framework within which kinship has generally been embedded is not adequate. That framework does not address the central question of why the Tongan kinship system has its particular kin categorizations that are expressed and defined through the kinship terminology. To address this question we present a formal, algebraically based account of the Tongan kinship terminology. The account is grounded in ethnographic observations from a variety of cultures about the way in which kinship terminologies are used to compute and to determine kin relations. The algebraic account makes evident the underlying logic of the terminology as a generative structure and allows us to distinguish between features of the kinship system that arise from the logic of the terminology as a generative structure and features that must have arisen through cultural intervention.

Finally, we revisit the ethnographic account. First, we highlight aspects of the ethnographic analysis with the firm foundation provided by the algebraic analysis. Second, we consider those aspects of the ethnographic account whose explication must lie in cultural interventions thus linking the kinship conceptual systems to other domains such as ranking and inheritance.

## 1. Tongan Social Life and Kinship

We start this section with an episode (a child's first birthday) that occurred to one of us (the senior author) during his residence in Tonga. The intention is to introduce the specific way in which the Tongan kinship system shapes social events such as child's first birthdays, marriages, and funerals and the issues related to kinship that these events pose.

It is a special day today in the village of Ngeleia, Tonga. Manu<sup>2</sup> and Mele's daughter Loisi,<sup>3</sup> their third child, is one year old. Traditionally in Tonga, the celebration of one's

---

<sup>1</sup> The use of the term genealogy is inconsistent in the anthropological literature. Sometimes it is used in the sense of actual or putative genetic/physical relationships, sometimes it is used in the sense of culturally defined relations modeled on biological relations and sometimes it is used in the sense of symbolic relationships. We use genealogy in the last sense and distinguish between a genealogy formed on the basis of tracing mother and father relations, however these might be locally defined, and a pedigree formed on the basis of tracing genetic mother and genetic father relations.

<sup>2</sup> Names have been changed as common practice in anthropology to maintain privacy of participants.

<sup>3</sup> The sex of the child would not bring any change in the episode I am about to narrate.

child's first birthday is one of the few social landmarks in a person's life—other two being marriage and one's funeral. Manu and Mele are living with Manu's parents and their house is not big enough to host the celebratory gathering and consumption of food. The celebration takes place in the hall next to the church located right in front of Manu's parents' house.

As I approach the hall, I see people carrying large pieces of *ngatu* 'tapa/barkcloth' or mats being met at the door by Mele. I get a glimpse of Manu, still in the backyard of his parents' house, cheerfully chatting with other men while finishing the roasting of a few small pigs over a hot fire. My attempt to move in his direction is interrupted by his clear invitation to proceed to the hall. When I enter the hall, to my right, stands Manu's sister Nunia (she is much younger than Manu) holding Manu's daughter, Loisi. Of course, they are dressed up for the occasion wearing their best *ta'ovala* 'mat worn around waist,' as are all the guests either sitting on the numerous chairs available or just standing and chatting in small groups. Behind and next to Nunia and Loisi, a pile of pieces of *ngatu* and mats with other presents like pieces of fabric, canned food, meat, and money is slowly forming.

One side of the hall is occupied by a few tables with tablecloths on which many plates full of food have been already put on display. After a few celebratory speeches performed by the minister and a few elder guests, and after roasted pigs have been put on the empty dishes waiting for them on the table, guests are invited to help themselves to the food. My memory fails me here about the many types of food available and the ones I actually managed to try. During the whole celebration Manu was nowhere to be seen. The focus of attention during the whole event were either Loisi or Nunia or Mele (Loisi's mother).

The celebration closed with Nunia choosing and keeping some of the presents for herself and with the remaining presents being distributed by her to some of the guests. After this distribution, almost all the guests left. Then, finally Manu entered the hall and had some food while gleaming with happiness about the successful completion of the celebration.

I must admit that I was already aware of the special role that the father's sister called *mehekitanga* plays in the life of Tongans, but witnessing its instantiation (see Read 2002) was quite a different experience. The *mehekitanga* of the celebrated child was the center of the whole ceremony. Presents were piled at her side, she chose how many to keep, and she decided which had to be given to the various departing guests. In the coming years, she would actively participate in the raising of the child, but especially exercise her privilege (called *fahu*) to ask and receive material objects and services from her brother's children. All sisters of a Tongan male will be *mehekitanga* to his children, but the eldest sister would be the only one exercising the privilege of her position.<sup>4</sup> The same *fahu* relationship exercised by one's father's sister (*mehekitanga*) over her brother's children

---

<sup>4</sup> In traditional Tonga this privilege was exercised by all *mehekitanga*. In contemporary Tonga this privilege is being often contested, especially when it is exercised in ways that tend to clash with the principles of a newly introduced market economy in a rapidly westernizing population (see Small, 1997; Morton, 1996; 2003).

(*fakafotu*, both male and female) is also exercised by any individual over their mother's brothers (*fa'e tangata*).<sup>5</sup>

A Tongan female sibling is always higher in rank than her brother, and an older same sex sibling (*ta'okete*) is always higher in status than a younger one (*tehina*) (Gifford, 1929; Tupouniua, 1977; Bott, 1982; Gailey, 1987; van der Grijp, 1993). The gender hierarchy is further stressed by the brother/sister or *tuonga'ane* (male sibling for a female)/*tuofefine* (female sibling for a male) avoidance practice (Gifford, 1929; Tupouniua, 1977; Helu, 1999). Siblings of different sex are moved into separate sleeping quarters around the age of ten. Specific linguistic (e.g., topics like sex) and behavioral restrictions (e.g., dancing, watching a movie) are also part of this avoidance system that continues throughout one's life.<sup>6</sup> This partly explains Manu's behavior and his late entrance into the hall.<sup>7</sup>

As important as this episode of a first year birthday is in highlighting the complex and fundamental interaction between kinship and social life, it does not compare with the relevance that funerals have as the most salient event in Tongan social milieu. The death of an individual start a series of events that constitute the mold into which kinship relationships are poured so as to establish the social position of that individual for the last time. The reiterative enactment of these events by the predetermined people/kin sets forth the conditions for the continuation of the form of praxis sometimes referred to as 'tradition.'

Tongan funerals are acts of intense privacy embedded in an array of behavior of vast social valence. In Kaeppler's words:

"An individual's funeral is probably his most important *rite de passage*, for at this time are recorded for all to see and to pass down through oral tradition how the individual was related to others, his dignity, rank, and how much and by whom he was beloved. Funerals are also the most important societal occasions, for here can best be seen how the various elements of Tongan society fit together and it is here that much of the enculturation of the young in Tongan tradition takes places". (Kaeppler, 1978:174)

People participating in this event all belong to the same *kainga* (bilateral kindred) and are constrained in their behavior by their kinship relationship to the deceased. "[F]unerals are the occasions *par excellence* when status and rank prescribe the actions of all concerned." (Kaeppler, 1978:174). Ranking in Tonga establishes who is high (*'eiki*)<sup>8</sup> and who is low (*tu'a*)<sup>9</sup> (Kaeppler, 1971; James, 1991; van der Grijp, 1993). We have already

---

<sup>5</sup> This type of *fahu* is also limited nowadays to "the eldest female child of the father's eldest sister." (Tupouniua, 1977:24).

<sup>6</sup> Many contemporary Tongans do away with separate sleeping quarters or avoiding the same dancing floor with one's opposite sex sibling, but the taboo is still very much in their consciousness and can still be cause of social embarrassment if broken.

<sup>7</sup> Traditionally cooks were also considered as the bottom of the society's ladder (see Martin, 1818) and this sentiment may have had a part in motivating Manu's behavior. After all, he had been preparing food all day up to the time of the birthday celebration.

<sup>8</sup> *'Eiki* also means 'chief.'

<sup>9</sup> *Tu'a* also means 'common people' and 'outside.'

seen how in the same generation female siblings are superior to males and older same sex siblings are superior to younger ones. This is true also of their descendants. In the generation above ego, the father side is *'eiki* and the mother side is *tu'a*. However, rank acquired through the mother is more important than rank acquired through the father. In the generation below ego, children of the deceased are *tu'a* if the deceased is male and *'eiki* if the deceased is female (Kaeppler, 1971).

Only relatives that are *'eiki* to the deceased are allowed to touch the body and prepare it for the burial. The person who sits at the head of the corpse during the wake is the *fahu*. In the case of a dead woman, typically the child of the deceased's 'father's sister' is the *fahu*. In the case of a dead man, a child of the deceased's 'sister' or grandchild of the deceased's 'father's sister' would be the *fahu*. All the relatives that are *tu'a* to the deceased belong to the *liongi* or group of people responsible for bringing presents that will later be distributed by the *fahu* after choosing some for personal use. The *liongi* are not allowed to touch the corpse or to enter the wake room where the corpse is lying, and they must wear an enormous mat around their waist (at times covering even the back of their heads) as an overt sign of their sorrow and status.

It is not our intention to provide here a detailed description of a Tongan funeral (examples of exhaustive treatments are Kaeppler, 1978; van der Grijp, 1993). What is of relevance to us is to make clear how knowledge of kinship relations is fundamental in regulating the unfolding of such a salient cultural event. Constitutive to this specific event is the fact that the only relationships that are considered effectual are those of each individual to the deceased and not of individuals among themselves. This fact will become increasingly relevant as the present work progresses.

One final aspect within the general funeral event needs to be illustrated because of its crucial importance to the focus of this work. During the first night of wake, after the *liongi* have brought their gifts, all the *'eiki* men usually form a circle either outside the house of the deceased or on the porch (or inside because of the weather) of the closest house of a relative and drink kava.<sup>10</sup> "It is during the wake that information about genealogical relationships is passed on to the following generations" (Kaeppler, 1978:197). While this may be true of only part of the waking congregation, it is definitely true of the kava drinking circle. Two major aspects of the genealogical discussions taking place must be pointed out. The first is the content, the major topic discussed is almost unavoidably the appropriateness of the chosen *fahu*. The second is the linguistic forms that characterize these discussions.

Regarding the assignment of the role of *fahu* to an individual, Kaeppler says:

"[T]he individual called to be *fahu* should go back in the ancestry of the father of the deceased to a brother or sister. Ideally this brother and sister should have chiefly blood, [...] The descendants of the sister of this sibling pair will provide the *fahu*." (Kaeppler, 1978:197)

---

<sup>10</sup> Kava is prepared by grinding dried roots of the *Piper methysticum* plant and then mixing the powder with water in a ceremonial bowl. The drink obtained is nonalcoholic but slightly narcotic.

Nowadays, Kaeppler continues, “with the progressive nuclearization of the family, the *fahu* called is often taken from only one generation back.” (1978:197). A similar phenomenon is also noted and described by Gailey (1987), by van der Grijp (1993), and by Small (1997). Notice, however, that the issue of modernization towards a focus on the family away from the *kainga* still leaves the necessity of assigning the role of *fahu* unaltered. A basic form of kinship calculation or computation still needs to be performed to arrive at the role assignment required.

As for the language in which this calculation is made, the discussion is mainly conducted by means of kinship terms and almost impossible to follow for an audience not familiar with them.<sup>11</sup> The starting point is the deceased person, but soon whatever genealogical space could be constructed on him/her is left behind to calculations and/or computations over this space conducted in the familiar kinship terminology. By familiarity we do not mean only the superficial linguistic knowledge of the terms (which one of us has), but most significantly the capacity to use the logic behind the terminology in quickly thinking about relationships.

For example, the construction of a genealogical space centered on an individual need not consider the gender of that individual (usually called ego). Similarly, in primary genealogical space (PGS) (see Lehman and Witz, 1974, 1979), gender discrimination logically need not be present initially in the generation above or below ego. Gender, though, of the individual under discussion (the deceased in our case) and of the other relatives considered, is crucial to the understanding of another individual as occupying the relational place of *fahu*. If male, his *'ilamutu* ‘sister's children’ or his *mehekitanga* ‘father's sister’ or his *tama mehekitanga* ‘father's sister's children’<sup>12</sup> (and so on) are *fahu* to him and his children are *tu'a* ‘low.’ If female, only her *mehekitanga* ‘father's sister’ or her *tama mehekitanga* ‘father's sister's children’ (and so on) are *fahu* to her and her children are *'eiki* ‘high.’

The conceptual content of the various kinship terms used in defining the *fahu* is more complex than the positions in PGS to which the transliteration of each term may refer.

---

<sup>11</sup> Bennardo was at one of these *faikava* in 1993 and from his fieldnotes he was able to reconstruct the following dialogue:

A: *Ko hai 'a e fahu?*

‘Who is the *fahu*?’

B: *Ko Sione*

‘Sione’

A: *Sai, ko Sione, ko e fahu tonu*

‘Right, Sione, the right *fahu*’

B: *'Io, tonu, ko 'ene fa'é ko e mehekitanga ki he Tomoua* (the deceased person)

‘Yes, right, his *fa'é* (‘mother’) is the *mehekitanga* (‘father's sister’) of Tomoua’

A: *'Io, ka ko e tuofefine 'a Sione sai ange 'o fahu*

‘Yes, Sione's *tuofefine* (‘sister’) is a better *fahu*’

B: *'Io, tonu, ka Mele 'ikai ke lava 'o ha'u ki heni mei Ausileleia*

‘Yes, right, but Mele could not come here from Australia’

A: *'Io, 'ikai ke lava*

‘Yes, she couldn't’

<sup>12</sup> Usually called *tokoua* ‘same sex sibling,’ *tuofefine* ‘sister to male,’ and *tuonga'ane* ‘brother to female.’

Conceptual complexity has been defined by Keller and Lehman (1991) as the function of three factors, a) internal increased content (e.g., cousin vs. father), b) the complexity of the domain/theory in which a concept is embedded, and c) polysemy (e.g., the English word, bank). In PGS an ego is not marked for gender. In Tongan kinship terminology there is no sexually unmarked ego term and when computing genealogy through kin terms (e.g., finding out who is the appropriate *fahu*) most of the terms used to make the calculation are gender marked. In Biersack's words: "In all terms, except those for children of opposite-sexed siblings, alter is identified as to gender relative to speaker." (Biersack, 1982:184). This small but substantial difference (among others, e.g., age) has important consequences when considering the relationship between the kinship terminology and PGS.

Other puzzling questions arise when one looks carefully at the Tongan kinship terminology, such as for example the different linguistic marking of sibling terms according to gender and age, the different linguistic marking of the term for FZ vis á vis MZ with the conspicuous role she (FZ) plays in many aspects of Tongan social life, and finally, the linguistic distinction provided in the terms that refer to older and younger maternal uncle (MB) that is not present in the symmetrical relationships among paternal aunts (FZ). None of these properties can be accounted for simply by reference to the genealogical space. Rather, they require that we delve into the logic of the kinship terminology. We will highlight these issues as they arise within the following brief presentation and discussion of the Tongan kinship terminology as a conceptual system since they are not features that can be isolated from the terminology viewed in its entirety.

## 2. The Tongan Kinship Terminology

The Tongan Kinship Terminology (TKT from now on) spans over five generations with generation 2 up and 2 down containing only a closure term, *kui* 'grandparent' and *mokopuna* 'grandchild,' respectively (information about TKT comes from Aoyagi, 1966; Beaglehole and Beaglehole, 1941; Biersack, 1982; Bott, 1982; Collocott, 1923, 1927; Gailey, 1987; Gifford, 1929; Helu, 1999; Kaeppler, 1971; Korn, 1974, 1978; Marcus, 1977, 1978, 1980; Martin, 1818; Morton, H., 1996, 2003; Morton, K., 1972; Rivers, 1916; Rogers, 1977; Tupouniua, 1977; van der Grijp, 1993; and from Bennardo's fieldwork in 1993-95). The three major generations (zero, 1 up, and 1 down) covered by the terminology contain between five and six terms each. Generation zero contains five terms: *tokoua* 'same sex sibling,' *tuofefine* 'sister of male,' *tuonga'ane* 'brother of female,' *ta'okete* 'older same sex sibling,' and *tehina* 'younger same sex sibling.' Generation 1 up contains six terms: *motu'a* 'parent,' *tamai* 'father,' *mehekitanga* 'father's sister,' *fa'é* 'mother,' *fa'é tangata* 'mother's brother,' and *tu'asina* 'mother's younger brother.' Generation 1 down contains five terms: *tama* 'child of female,' *foha* 'son of male,' *'ofefine* 'daughter of male,' *fakafotu* 'child of *tuonga'ane*,' and *'ilamutu* 'child of *tuofefine*.'

Table 1 lists the set of Tongan kin terms just introduced with partial genealogical descriptions for each kin term.

All the terms in generation zero (*tokoua*, *tuofefine*, *tuonga'ane*, *ta'okete*, and *tehina*) are also used for genealogical parallel cousins and cross-cousins<sup>13</sup>, without regard to linking relative, so Tongan cousin terminology is Hawaiian (Biersack, 1982:184) if one uses Murdock's classification (but see below for why this is misleading). Nonetheless there is a behavioral distinction between genealogical parallel cousins and cross-cousins (Biersack, 1982:184; Kaeppler, 1971:177). In fact, individuals would behave towards the two types of cousins in the same way as their parents do, and these latter distinguish them terminologically (i.e., using either '*fakafotu* 'child of tuonga'ane' or '*ilamutu* 'child of tuofefine.' Then, "[T]he way persons reference and behave toward each other depends upon their own sibling relationship (parallel or cross-) or (for collateral kin) their parents' sibling relationship." ((Biersack, 1982:184).

**Table 1:** Terms From the Tongan Kinship Terminology

<u>Generation</u>	<u>Term</u>	<u>Partial Genealogical Description</u>
<b>2 UP</b>	<i>KUI</i>	(FF, FM, MM, MF)
<b>1 UP</b>	<i>MOTU'A</i>	(M, F)
	<i>FA'E</i>	(M, MZ)
	<i>FA'ETANGATA</i>	(MB)
	<i>TU'ASINA</i>	(younger MB)
	<i>TAMAI</i>	(F, FB)
<b>ZERO</b>	<i>MEHEKITANGA</i>	(FZ)
	<i>TOKOUA</i>	(same sex B, Z)
	<i>TUOFEFINE</i>	(Z of male)
	<i>TUONGA'ANE</i>	(B of female)
	<i>TA'OKETE</i>	(older B, Z)
<b>1 DOWN</b>	<i>TEHINA</i>	(younger B, Z)
	<i>TAMA</i>	(S, D of female)
	<i>FOHA</i>	(S of male)
	<i>'OFEFINE</i>	(D of male)
	<i>FAKAFOTU</i>	(BS, BD of female)
<b>2 DOWN</b>	<i>'ILAMUTU</i>	(ZS, ZD of male)
	<i>MOKOPUNA</i>	(SS, SD, DS, DD)

The behavior that distinguishes between genealogical parallel and cross-cousins is named *fahu* (see previous section), where one is '*eiki* 'high' to one's mother's brother's children and is '*tu'a* 'low' to one's father's sister's children. Why this shift from labeling persons by kinship terms to labeling the relationship between persons without simultaneously labeling the persons involved in different relationships? Why this gap in the terminology? Or better, is this to be considered a gap? Or is there enough

---

<sup>13</sup> We use an expression of the form 'genealogical relative,' to make it clear that the relation in question neither has to do with biological relations nor is it limited to the kind of relative stated in the expression; that is, 'genealogical parallel cousin' includes not only one's parallel cousin in a genealogical sense but all other genealogical relations included by the Tongan under the kin term with transliteration 'genealogical parallel cousin.'

computational power in the terminology already to make the addition of further terms unnecessary? Furthermore, why distinguish between siblings only according to gender and age (but only in some cases)? And then, why only one term for same sex sibling? We will address and answer all these questions after we present a formal (algebraic) analysis of the structural logic of the TKT.

The term *motu'a* 'parent' in the generation 1 up is very rarely used with the glossed meaning. Only few people ever accept it as a cover term for both parents, and if so, they prefer to use it to refer to father more than to mother. However, its presence in this generation of the TKT parallels that of *tokoua* 'same sex sibling' in generation zero, that of *kui* 'grandparent' in generation 2 up, that of *tama* 'child of female,'<sup>14</sup> and that of *mokopuna* 'grandchild' in generation 2 down. It seems that the five terms (from up to down: *kui*, *motu'a*, *tokoua*, *tama*, and *mokopuna*) may constitute the backbone of the whole TKT structure; in other words, they are the less complex conceptual elements. In fact, they only identify persons in each of the five different generations whose respective dual relationship is that of parent/child (lineality) without any regard to sex or relative age at the same generation level.

The other four terms in generation 1 up, namely, *tamai* 'father' and 'father's brother,' *fa'é* 'mother' and 'mother's sister,' *mehekitanga* 'father's sister,' and *fa'é tangata* 'mother's brother,' represent terms that are constituted by adding further conceptual material such as gender and siblinghood. The terms *tamai* and *fa'é* are also applied to the same sex siblings of father and mother (and other genealogical relations), respectively. This continues to highlight the saliency of the relationship between same sex siblings expressed in generation zero by the single term *tokoua*. Cross-siblings (parent's) are instead named in the same way as in generation zero by two different terms. But while on the father's side the term *mehekitanga* 'father's sister' stays the same irrespective of age (all father's sisters are *mehekitanga*), on the mother's side the term *fa'é tangata* 'mother's brother' changes according to age. In fact, the term *tu'asina* is used to indicate the mother's younger brother.

What are the regularities and repetitions of conceptual content (e.g., same sex siblings indicated by same term) in generation zero terms and in generation 1 up terms indicating about the underlying logic used for the construction of the TKT? Is the basic logic for generation 1 up terms already present in generation zero terms? Why are more specifications made (i.e., terms) on the mother's side (*fa'é tangata*, *tu'asina*) than on the father's side (*mehekitanga*)? These questions too will be addressed in a later part of this work.

Finally, the five terms in generation 1 down display partly similar conceptual content as those in generation zero, but in a different combination than those in generation 1 up. *Tama* 'child of female' is not marked for sex, but the node by which it is reached must be female. On the other hand, both *foha* 'son of male' and *'ofefine* 'daughter of male' are marked for sex and need to be reached through a male node. These three terms are also

---

<sup>14</sup> This term that is now restricted to child of female, might have been used for both (female and male) in the past. We will discuss this issue later. Furthermore, see also the two terms *fakafotu* 'child of tuonga'ane' and *'ilamutu* 'child of tuofefine' in generation 1 down that lack any gender specification.

applied to children of one's same sex siblings or *tokoua*. Both *fakafotu* 'child' of *tuonga'ane* and *'ilamutu* 'child' of *tuofefine* are not marked for sex, but they need to be reached by two nodes marked for sex (e.g., female → male sibling → child for *fakafotu* or male → female sibling → child for *'ilamutu*). These last two terms are also used for children of genealogical parallel cousins and cross-cousins in accordance with the fact that genealogical parallel and cross-cousins are addressed as *tuonga'ane* and *tuofefine*, depending on gender.

It seems as if gender has salience only when reference is made to a male's offspring (*foha* or *'ofefine*). The general tendency of the terminology at this generation level is not to mark for gender (see *tama*, *fakafotu*, *'ilamutu*). Why? Is this part of the internal logic of the TKT? Or is this the result of cultural interventions that are skewing the otherwise lack of gender marking in the generation 1 down terms? The answers to these questions, including all the other ones already introduced in this section, will be found during our treatment of the TKT that follows.

### 3. Structural Analysis of TKT: Preliminaries

The (extensionist) received view of kinship systems presumes that kin terms are labels for categorizations made of kin type products in the genealogical space and the meanings of kin terms are extended from a primary categorization of kin type products to more distant kin type products. Thus a term such as *fa'é* 'mother' is assumed to have the primary meaning of mother (= genetrix) and the term *fa'é* is then, according to the extensionist received view, extended to other females such as (but not limited to) mother's sister. Left unanswered, though, are the criteria upon which the presumed categorizations and the reasons for the extensions are based. The extensionist view of kinship terminologies takes the set of kin terms making up a terminology as a given and does not account for the particular terms making up the terminology. Nor does it account for the pattern of extensions for the terms in the kinship terminology.

We argue, instead, that it is more fruitful to consider that two conceptual systems are involved. One conceptual system relates to the logic underlying the structural form of the genealogical space (see Lehman and Witz, 1974, 1979). The other conceptual system relates to the logic underlying the structural form of the terminological space formed from the way kin terms form a symbolic system in their own right via a kin term product (defined below) and not as a structure derived from the genealogical space (Read 1984, 2001a; Read and Behrens 1990) (see Figure 3, below). We will account for the particular set of terms making up the Tongan terminology by showing how the Tongan terminological space can be generated from a small set of primary kin terms and structural equations that determine the form of the structure generated from the primary kin terms. What are called kin term extensions in the extensionist received view can then be derived as predicted genealogical definitions from the generative logic underlying the Tongan terminological space by mapping the generating kin terms onto the genealogical space.

The extensionist received view fails to realize that two conceptual systems are involved: (1) a genealogical space based on tracing genealogical connections from a focal individual and (2) a terminological space based on the way kin terms are computed

directly using a kin term product of kin terms (discussed below). Lack of a clear distinction between these two realms is conducive to unavoidable misrepresentations of both. Here are two examples illustrating the problem with restricting analysis of a kinship terminology to features in a genealogical framework alone.

### 3.1 Genealogical Feature Analysis

Biersack (1982), presents an analysis of Tongan exchange structures by making reference to the people involved as occupants of nodes in a genealogical space (Figure 1).

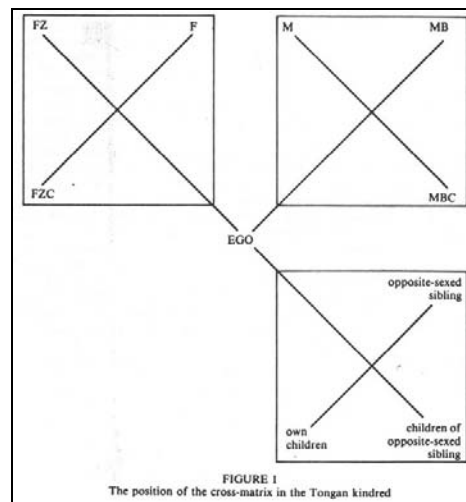

**Figure 1:** Part of Tongan Genealogical Space (from Biersack, 1982:186)

Her exercise, though, obliges her to introduce variants of the typical symbols used in representing a genealogical space. In fact, because she has the TKT in mind, and because she is centering the genealogical space on Ego, she cannot express the terms *tuonga'ane* (male sibling for a female) and *tuofefine* (female sibling for a male) with the symbols used to represent the genealogical space. Consequently she introduces the unconventional solution of labeling a node in a genealogical space by a linguistic expression such as 'opposite-sexed sibling.' But 'opposite sex sibling' is not a feature of the genealogical space and instead refers to a transliteration of the kin term *tuofefine*. Thus she is conflating information about the two realms of a genealogical space and a kinship terminology space.

Similarly, when trying to represent the TKT, van der Grjip (1993) maps it onto a genealogical space centered on a hypothetical Ego. Consequently, he produces a seriously limited representation of the terminology (Figure 2).



Products of kin terms may be defined through their referential usage in a manner consistent with ethnographic observations about kin calculations. Consider three individuals labeled ego, alter and alter\*. If K and L are two kin terms from a kinship terminology, the product  $K \times L$  becomes the kin term that ego would (properly) use to refer to alter\* where K is the kin term that ego (properly) uses to refer to alter and L is the kin term that alter (properly) uses to refer to alter\* (see Sahlins 1962 for a discussion of how computations are made with kin term products). For example, for the American Kinship Terminology, Father is an atomic term whereas Grandfather is a compound term since it is the product of the atomic term Father with the kin term Parent. That is, Grandfather = Father  $\times$  Parent, (read "Grandfather is Father of Parent"), for if ego (properly) refers to alter by the kin term Father and alter (properly) refers to alter\* by the kin term Parent, then ego (properly) refers to alter\* by the kin term Grandparent.

Once we have formed the kin term map, we then determine whether the claim that the structure displayed in the kin term map has an underlying generative logic is valid or not. In general, structures formed on an ad hoc basis almost certainly do not have an underlying generative logic. Establishing that a terminology structure has an underlying generative logic justifies considering the kinship terminology as a conceptual structure in its own right and one whose logic can be understood without necessary reference to the genealogical space.

In our analysis we infer from the kin term map what appear to be the underlying kin term equations for generating the structure displayed in the kin term map. We validate the claim that the kin term map has an underlying generative logic by constructively determining if it is possible to generate the kin term map exactly (i.e., isomorphically) from the inferred equations (Read and Behrens, 1990; Read, 1997, 2000, 2001a, 2001b). Failure to isomorphically generate the kin term map would constitute falsification of the claim that the kin term map has an underlying generative logic. If the claim is validated for the TKT, delineation of this generative logic will help answer the questions raised in the previous section.

### 3.2 Kin Term Attribute Analysis

Before considering in detail the analysis of the kin term map for the TKT that was undertaken by using the computer program KAES<sup>15</sup> (Read and Behrens, 1990; Read and Fischer 2004), we first present a preliminary analysis of the TKT based on attributes of kin terms. We will use the kin term attributes gender marking (male and female) and relative age (older and younger) as well as our distinction between an atomic term, and a compound term.

---

<sup>15</sup> The software program KAES (Kinship Analysis Expert System) may be downloaded from the webpage located at <http://kaes.anthrosciences.net/>.

**Table 2:** Attribute Analysis of Tongan Kinship Terms

generation	Atoms			compounds		
	- gender	+ gender		- gender	+ gender	
		+ male	+ female		+ male	+ female
<b>2 up</b>				<i>kui</i>		
<b>1 up</b> younger	<i>motu'a</i>	<i>Tamai</i>	<i>fa'e</i>		<i>fa'etangata</i> <i>tu'asina</i>	<i>mehekitanga</i>
older <b>zero</b> younger	<i>ta'okete</i> <i>tokoua</i> <i>tehina</i>	<i>tuonga'ane</i>	<i>tuofefine</i>			
ZS, ZD of male <b>1 down</b> BS, BD of female				<i>'ilamutu</i> <i>tama</i>		
				<i>fakafotu</i>		
<b>2 down</b>				<i>mokopuna</i>		

In Table 2, we indicate the atomic and the compound terms, and their distribution according to the attributes gender and age by generation. If we reduce the terminology to atomic terms without gender or age attributes we obtain the following structure—notice the centrality of the term *tokoua*:

1 up	<i>motu'a</i>
zero	<b><i>tokoua</i></b>
1 down	<i>tama</i>

By adding gender to this 'atomic' base, we obtain the following structure—again, notice the centrality of the term *tokoua*:

	<u>Female</u>	<u>Neutral</u>	<u>Male</u>
1 up	<i>fa'e</i>	<i>motu'a</i>	<i>tamai</i>
zero	<i>tuofefine</i>	<b><i>tokoua</i></b>	<i>tuonga'ane</i>
1 down	<i>'ofefine</i>	<i>tama</i>	<i>foha</i>

The addition of age within the same generation does not change the central position of the term *tokoua*:

	<u>Female</u>	<u>Neutral</u>	<u>Male</u>
1 up	<i>fa'e</i>	<i>motu'a</i>	<i>tamai</i>
zero	<i>tuofefine</i>	<i>ta'okete</i> <b><i>tokoua</i></b> <i>tehina</i>	<i>tuonga'ane</i>
1 down	<i>'ofefine</i>	<i>tama</i>	<i>foha</i>

Similarly, even after adding compound terms the centrality of *tokoua* is left unaffected:

	<u>Female</u>	<u>Neutral</u>	<u>Male</u>
2 up		<i>kui</i>	
1 up	<i>fa'e</i> <i>mehekitanga</i>	<i>motu'a</i>	<i>tamai</i> <i>fa'etangata</i> <i>tu'asina</i>
zero	<i>tuofefine</i>	<i>ta'okete</i> <b><i>tokoua</i></b> <i>tehina</i>	<i>tuonga'ane</i>
1 down	<i>'ofefine</i>	<i>tama</i> <i>ilamutu</i> <i>fakafotu</i>	<i>foha</i>
2 down		<i>mokopuna</i>	

The structure displayed in the last diagram is not due to mapping the kin terms onto the genealogical space but instead arises from the logic of the terminological space that informs us as to the structural relationships among the kin terms in the terminological space displayed via a kin term map. One of the key aspects of a terminological space is the term (in some terminologies) or terms (in the case of the Tongan and other classificatory terminologies) that is at the 'center' of the structure. Read calls such a term (or terms) the focal term(s) for the terminology. According to Read (1997:22), a 'focal' term represents the 'center' of the kin terminology structure and is determined from the structural properties of the terminological space and does not have a priori specification such as ego in the genealogical space. The focal term is an identity element, either for the full terminology or for the terms having a single sex marking (to be discussed below). The focal term(s) plays a role in the kin term map analogous to the ego position in the typical idealized genealogical grid used to partially display the structure of the genealogical space and is critical to the notion of reciprocal kin terms.

Tongan kinship terminology lacks any term that might correspond to the English term 'ego.' We want to point out that in English the term 'ego' does not belong to folk labels for positions in the genealogical space, but instead is a concept introduced and used by scholars. It was invented by 'experts' to graphically display a genealogical space and

hence it is not unusual to find out that it is not linguistically realized universally. The lack of a kin term that “corresponds” to ego does not imply that the Tongan kinship terminology is not “ego-centric” since in our analysis the “ego-centeredness” of a kinship terminology arises from its structural form and the focal term(s) for the terminology. The focal term(s) is a conceptual position in the structure that provides the structural basis for one kin term to be the reciprocal of another kin term (see below). The focal term is mapped to an individual when the terminology is instantiated in usage and the person to whom the focal term is mapped (that is, the person who is being identified as the self in the domain of discourse) determines the person from whom kin term reference is expressed. In the American kinship terminology the focal “term” is Self; in the TKT there is no kin term that can be glossed as Self. Instead, as we will demonstrate, the focal terms are *tuonga'ane* (‘brother (ws.)’) and *tuofefine* (‘sister’ (ms.)). The reason why these are the focal terms arises from the very core of the logic underlying the TKT and is not immediately apparent from our preliminary analysis.

After looking at the various structures considered above, it seems, at first glance, that the term *tokoua* ‘same sex sibling’ should be the focal term of the terminology structure.

However, rather than simply accepting this impressionistic conclusion, we need to demonstrate the centrality (or lack thereof) of the term *tokoua* in the kin term structure. To do so we need to work out the logic of the TKT and to determine if the kin term map for the TKT (which displays the structure of the TKT) can be generated from first principles. If so, then the status of the term *tokoua* will be clarified by reference to that structural logic. Though it appears to be a candidate for a focal term, it will be shown that instead of being a focal term, *tokoua* is structurally the central concept for the notion of siblinghood in the TKT. The focal terms for the structure are then found to be *tuonga'ane* ‘brother (ws.)’ and *tuofefine* ‘sister (ms.)’

In addition, the algebraic analysis of the TKT map will provide illustrative data about the inherent logic of TKT as a system of symbols. We will use this logic to construct an explanatory argument for the structural properties of TKT discussed above and to identify features of the kinship terminology that do not have a structural origin. For the latter set of features we must look to Tongan culture to make sense of their presence in the TKT. Finally, we will use implications of the logic underlying the structural form of the TKT for clarifying the social usage of kin terms in the Tongan cultural milieu.

This is the summary of the major issues about TKT we have raised so far: 1) siblings are distinguished only according to gender and age; 2) the linguistic distinction between older (*fa'etangata*) and younger (*tu'asina*) maternal uncle is not present in the symmetrical position of paternal older and younger aunts (*mehekitanga*); 3) The general tendency of the terminology at generation 1 down is not to mark for gender (e.g., *tama*, *fakafotu*, *'ilamutu*), but oddly gender is used when reference is made to a male's offspring (i.e., *foha* or *'ofefine*); 4) *fahu*, where one is *'eiki* ‘high’ to one's ‘mother's brother's children’ and is *tu'a* ‘low’ to one's ‘father's sister's children,’ is not a kinship term; 5) At a Tongan funeral, in the generation 1 up, the father side is *'eiki* ‘high’ and the mother side is *tu'a* ‘low;’ in the generation 1 down, children are *tu'a* if the deceased is male and *'eiki* if the deceased is female; 6) there is a term for ‘same sex sibling, *tokoua*, but no corresponding term for ‘opposite sex sibling.’

## 4. An Algebraic Analysis of TKT

### 4.1 Kinship Terminologies and Genealogical Spaces

According to conventional wisdom, a kin terminology is, first of all, a classification system for a genealogical space. The conventional view that a kinship terminology is first of all a classification system for a genealogical space only makes sense if what is being classified is ontologically prior to the terminology.. Biological reproduction satisfies this criterion, hence the usual assumption that a terminology provides a classification for the possible positions in a genealogical space viewed as a cultural model based on, but not necessarily identical to, biological reproduction.

There are four major problems with this assumption, though. First, it assumes that a genealogical space modeled on biological reproduction is the universal basis for kinship in human societies. Secondly, it is not in accord with ethnographic observations showing that kin relations expressed in the form of kin terms are frequently determined by reference to calculations with kin terms directly and not first through construction of genealogical relations. Third, it incorrectly presumes a universal set of genealogical relations that constitute a genealogical space. And fourth, it leaves unexplained the basis for the particular distinctions made within a kinship terminology and the conceptual differences between kinship terminologies.

The notion of a universal genealogical grid as a universal basis for kinship has been extensively critiqued by Schneider (1984; see also Read 2001b) and requires discounting of ethnographic examples of societies where the male sexual role is not culturally recognized in terms of what constitutes a ‘father.’ In addition, it is perhaps surprising that Rivers’ (1924) presumption of kinship defined in terms of genealogy has survived as long as it has despite extensive ethnographic evidence to the contrary, including examples provided by Rivers that are contrary to his genealogical claim. While calculating genealogical connections between some individuals may be universal, it does not follow that all kin relations are determined by first establishing the genealogical connection of one individual to another. In one society after another ethnographers note that calculations are made of the kin relationship of one person to another by using products of kin terms without reference to a genealogical relations. For example, Sahlins comments :

“... [kin] terms permit comparative strangers to fix kinship rapidly without the necessity of elaborate genealogical reckoning – *reckoning that typically would be impossible*. With mutual relationship terms all that is required is the discovery of one common relative. Thus, if A is related to B as child to mother, *veitanani*, while C is related to B as *veitacini*, sibling of the same sex, then it follows that A is related to C as child to mother although they never before met or knew it. *Kin terms are predictable. If two people are each related to a third, then they are related to each other.*” (Sahlins 1962:155, emphasis added).

And in a review of Scheffler’s book *Australian Kin Classification*, Shapiro observes that his (Shapiro’s) informants “were generally more comfortable operating through the relationship terminology; it made little or no personal or social difference to them whether

(say) an alleged brother of the MM was in fact a MMB or a more remote ‘brother’ of the MM ...[they] easily decode the messages ‘aunt’s children’ and ‘X’s children’ *but not the message ‘father’s sister’s children’*. . . . (Shapiro 1982: 275, 274, emphasis added). Similar comments disconfirming the priority of genealogy in calculations of kin relationships can be found in Behrens (1984) for the Shipibo of Peru, Marshall (1976) for the !Kung san, among others. These ethnographic examples highlight the fact that kin relations are determined directly from the way in which kin terms form an internally organized structure of concepts and kin relations are computed using these kin terms without reference to a supposedly universal set of genealogical relations for the computation of kin relations.

A problem with assuming a universal set of genealogical relations for the computation kin relations arises with kin terms such as *ta’okete* and *tehina* in the Tongan terminology and their transliteration, ‘older same sex sibling’ and ‘younger same sex sibling,’ respectively. For these terms the genealogical relations  $b+$  (older genealogical brother) and  $b-$  (younger genealogical brother) for males and  $z+$  and  $z-$  for females must be added to the genealogical space for there to be genealogical products classified by *ta’okete* or *tehina*. But if the only reason to include  $b+$ ,  $b-$ ,  $z+$ , and  $z-$  as part of the set of genealogical relations comprising a genealogical space is to have a genealogical relation in the genealogical space that can be classified by *ta’okete* or *tehina*, then the enterprise has become circular and any claim that the genealogical space, *as a whole*, ontogenetically precedes the production of kin terms that provide a classification of the genealogical space cannot be sustained

Even assuming we could provide criteria for including genealogical products that do not depend upon reference to the terminology, we are still left with the question of why the Tongan terminology, for instance, has its particular list of kin terms and classes of genealogical products subsumed under each term and not some other set of terms and sets of genealogical products. Leach attempted to answer this question for the Jinghpaw Kuchin (1945) and the Trobriand (1958) by reference to social groupings that were important to an individual born into the societies in question and asserted, for the Trobriand terminology, that “when the kinterms are projected onto a genealogical diagram ... the underlying logic is utterly incomprehensible” (Leach 1958:140, as quoted in Lounsbury 1965: 146). Leach was right in presuming that if the distinctions made by the terms arise from prior social facts, then mapping terms onto a genealogical diagrams would likely lead to obfuscation rather than clarification, but he was wrong in assuming that the kin term distinctions reflected prior social facts. Lounsbury’s reanalysis of the Trobriand terminology showed, contrary to Leach’s claim, that there was a logic to the way in which Trobriand kin terms are mapped onto genealogical positions, but Lounsbury (1965:182) erred in implying that his method of rewrite rule analysis based on allegedly primary and extended meaning of kin terms expressed the underlying logic. What Lounsbury provided was simply a *description* of how his definition of primary and extended meanings played out when applied to a kinship terminology after it has been

distributed over a genealogical space (Buchler and Selby 1968; see also Read 2000, 2001a).<sup>16</sup>

These empirical and conceptual problems that arise when one assumes the genealogical space constitutes the single domain through which kin relations are determined are resolved if we consider the kin terms making up a terminology to be a structured set of concepts distinct from the genealogical space, as shown in the upper part of Figure 3. Rather than imposing a single basis for the definition of who are one's kin, the ethnographic evidence implies that there are, conceptually, two ways we consider individuals to be our kin. One is through the tracing of relations that characterizes the genealogical space and the other is based on the logic through which the kin terms form a conceptual system of kin relations and not simply a list of semantic labels. The two conceptual systems are linked through the genealogical definitions of kin terms, but the latter are not the primary means for expressing the semantic and syntactic structure that makes the domain of kin terms into a conceptual system (Read 2001b).

If the form and structure of kin relations expressed through kinship terminologies does not arise out of the phenomenological level of the facts of reproduction expressed via genealogical relations, then we need an ontologically prior foundation for the form and structure of both the genealogical and the terminological basis for expressing kin relationships. This will need to be a foundation that arises out of the ideational level rather than the phenomenological level of behavior, though it has implications for behavior. There are, minimally, three primitive concepts involved (see top box, Figure 3):

- (1) the concept of self
- (2) the concept of a relation (as expressed mathematically) and
- (3) the concept of recursion.

By "concept of self" is meant the conscious awareness of one's own existence, in contrast to the existence of others, as a sentient being (see Mead 1967[1934]: 135-226). The concept of self, along with the concept of mind, is possibly a unique feature of *Homo sapiens* (Byrne and Whiten 1997: 10). For analytical purposes, the idea that a person, X, has a concept of self can be formally represented as a predicate with one argument; i.e., Self(X), where Self is the predicate and X is the argument and Self(X) is true if X has the self concept; e.g., person X has a concept of self – a claim that presumably is true for the members of the species *Homo sapiens*.

---

<sup>16</sup> Regardless of the relationship between terms and a genealogical space, Lounsbury's rewrite method could not fail since it was an unrestricted writing system. With an unrestricted writing system one can always find rewrite rules that would allow a supposedly extended meaning to be recovered from an allegedly primary meaning of a kin term for *any* distribution of kin terms over a genealogical space.

The "success" of the rewrite method lies not in forming rewrite rules, per se, but in the auxiliary fact that a seemingly small number of rewrite rules "works" for a wide variety of terminologies (D'Andrade 1970). That a few rules seemed to work for many terminologies implies there must be an underlying logic to the way in which kin terms relate to a genealogical space, but the rewrite rule analysis does not establish the nature of that logic. And in fact it cannot as the rewrite rule analysis takes as a given precisely what needs to be explained, namely the form of the structure of a kinship terminology viewed as a system of symbols (= kin terms). It is precisely that logic that is addressed by the algebraic analysis.

Let us refer to a predicate with an unspecified value for an argument taken from a specified domain as a proposition over that domain; e.g., for the domain of primates,  $\text{Self}(\_)$  would be a proposition whose argument is some primate. Let us call the output of a proposition over a domain based on a predicate,  $P$ , to be all those entities in the domain for which the predicate  $P$  is true when the entity in question is the argument for the predicate. Thus for a domain called  $D$ , the output of  $\text{Self}(\_)$  would be all those entities,  $d$ , from the domain  $D$  for which the proposition  $\text{Self}(d)$  is true (or accepted as true). If the domain  $D$  consists of all humans, for example, then should  $d$  be bound to a particular human, say, the person named Mary, then  $\text{Self}(\text{Mary})$  is presumably valid since we accept the notion that members of our species have a concept of self (that is, Mary has a concept of self) and so Mary would be included in the output of the proposition  $\text{Self}(\_)$  over the domain  $D$  of humans.

By “concept of a relation”<sup>17</sup> is meant that for entities in some domain one entity can be linked to another entity by means of a criterion (or criteria) that the pair of entities satisfy. Among other possibilities, the criterion can be a biological or physical attribute, or it might be a conceptual distinction. As an example of the latter, we can speak of a genealogical mother relation between persons  $A$  and  $B$  when  $B$  is the female recognized by the members of a group as the genetrix of  $A$ . This type of concept formation apparently occurs with macaques (Dasser 1988).

A relation such as *genealogical mother* can be formally represented as a predicate, label it  $\text{GenMo}$ , with two arguments; e.g., we write  $\text{GenMo}(X, Y)$ , where  $\text{GenMo}$  is the predicate, “is a genealogical mother of”, and  $X$  and  $Y$  are its two arguments. We interpret  $\text{GenMo}(X, Y)$  to be true if  $X$  is the genealogical mother of  $Y$ . (We are using the convention that the second argument is the reference person and the first argument is the purported genealogical mother,  $X$ , of  $Y$ .) In this example the arguments for the relation are part of the phenomenological domain.

The arguments of a relation can also be part of the ideational domain. We can define a relation,  $\text{Father}$ , over the kin terms of the American Kinship Terminology by asserting that the proposition  $\text{Father}(K, L)$  is true for the *kin terms*  $K$  and  $L$  from the AKT when the kin term product (discussed in detail below), “Father of  $K$  is  $L$ ” is valid according to native users of the AKT. Thus for users of the AKT,  $\text{Father}(\text{Mother}, \text{Grandfather})$  is true since, *with respect to kin terms*, Father of Mother is Grandfather. The output of the proposition,  $\text{Father}(\_, \_)$ , would be all those kin terms  $K$  and  $L$  in the AKT for which  $\text{Father}(K, L)$  is true for kin terms; that is, Father of  $K$  is  $L$  is a culturally valid construct.

---

<sup>17</sup> The word, relation, is being used here in its mathematical sense and not in its ordinary usage sense as a cover term for ones relatives.

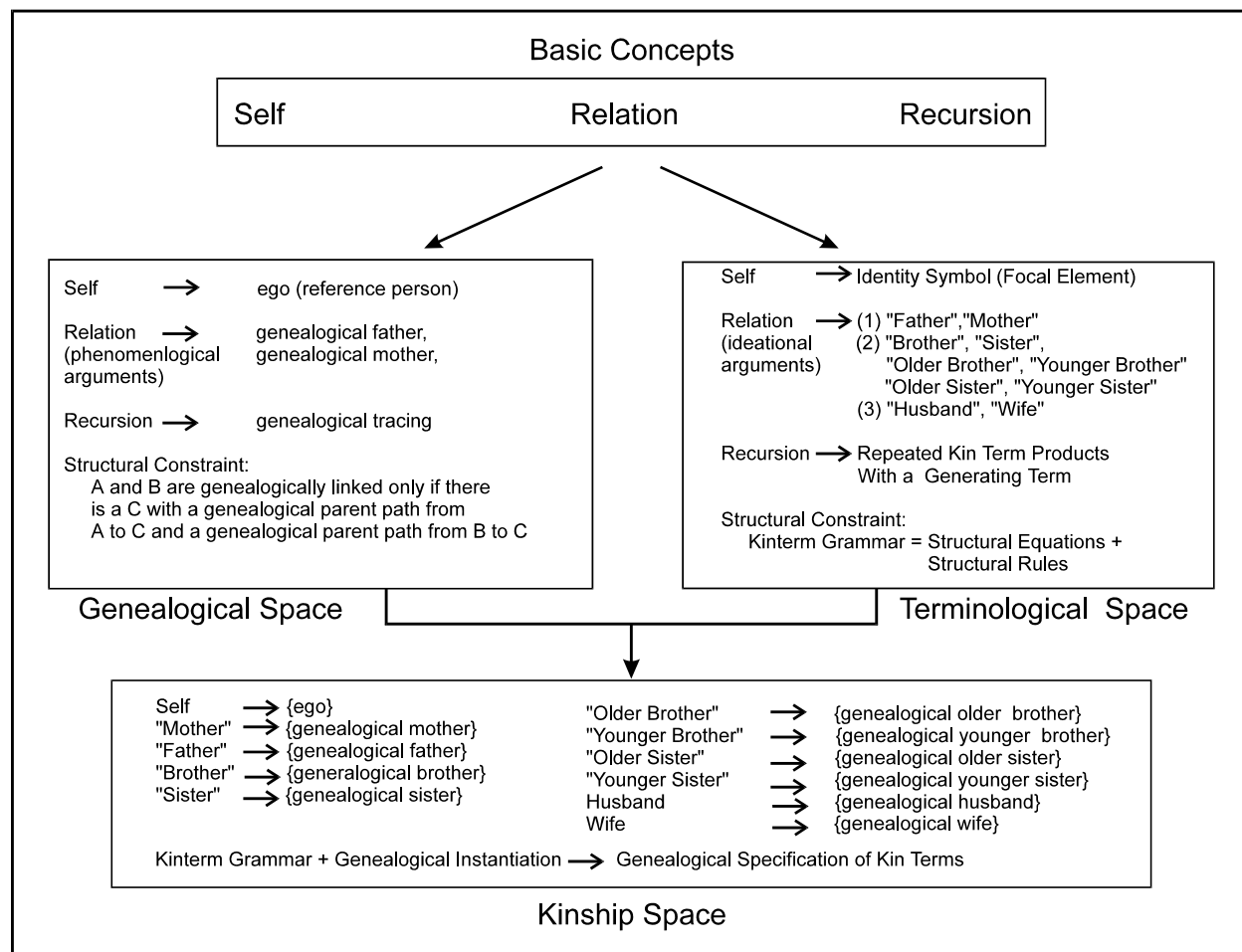

**Figure 3:** Concepts underlying genealogical space, kin term space and kinship space.

By “concept of recursion” is meant the idea that the output of a rule or algorithm can be treated as the input for that rule. Recursion is the basis, for example, for genealogical tracing as we will now discuss as a way to illustrate the idea of recursion. Suppose we have the rule: “Associate with a (specific) self the person X recognized as having the genealogical relation, genealogical father, vis-à-vis that self.” Thus if we begin with self as referring to, say, “me”, and if we determine the person X who has the genealogical relation father vis-à-vis me, then we can recursively consider self as referring to X and apply the rule to X to arrive at the person Y who has the genealogical relation, genealogical father, to the person X, and so on.

Formally, a recursive proposition is one in which an argument of the predicate is a proposition, including the proposition formed from that predicate. Using the genealogical mother relation defined above, then for person C we can form the proposition  $GenMo(\_, GenMo(\_, C))$  and the output of this proposition would be all persons A and B where B is

the genealogical mother of C and A is the genealogical mother of B; that is,  $\text{GenMo}(A, B)$  is valid and B is in the output of the proposition  $\text{GenMo}(\_, C)$ .

In the above example, A is also the genealogical grandmother of C. We can use this fact to define a new predicate,  $\text{GenGrandMo}$ , with two arguments by asserting that  $\text{GenGrandMo}(X, Z)$  is valid if there is a Y with both  $\text{GenMo}(Y, Z)$  and  $\text{GenMo}(X, Y)$  forming valid propositions. We can also use the variable, *ego*, to indicate an (abstract) starting point for the recursion. That is, we can write  $\text{GenGrandMo}(\_, \text{ego})$  and then later assign a specific person, say John, to be the value of *ego*. With the specification,  $\text{ego} \rightarrow \text{John}$ , the output of  $\text{GenGrandMo}(\_, \text{ego})$  would now be all those persons A such that there is a person B with  $\text{GenMo}(A, B)$  and  $\text{GenMo}(B, \text{John})$  both considered to be valid statements; that is, A is the genealogical mother of B and B is the genealogical mother of John. The effect of using the variable *ego* is to provide a non-specified “starting point” for the structure of genealogical relations that can then be applied to a specific person selected as *ego*.

These three concepts, self, relation and recursion, along with the idea of a reciprocal genealogical relation, underlie the production of the genealogical space as a conceptual system (see middle left box, Figure 3). A reciprocal genealogical relation may be viewed as the inverse relation for a relation. For example, for the genealogical relation  $\text{GenFa}$  (read “genealogical father”) we can define the relation  $\text{GenSo}$  by asserting that  $\text{GenSo}(X, Y)$  is valid if  $\text{GenFa}(Y, X)$  is valid, and similarly for  $\text{GenDa}$  and  $\text{GenMo}$ . Finally, we restrict the possible (consanguineal) genealogical relations that can be constructed through recursion by specifying what pattern of recursions lead to valid genealogical tracings according to how cultural bearers construct genealogical paths. A commonly used constraint limits genealogical tracing to either upward tracing only from *ego*, downward tracing only from *ego*, or up tracing from *ego* and then downward tracing<sup>18</sup>. These are paths that stay within the consanguineal space in which *ego* is embedded.

The three concepts also underlie the production of the terminological space represented by the kinship terminology (see middle right box, Figure 3) as will be shown below in Sections 4.2 and 4.3 for the Tongan terminology. For the terminological space the entities in question are the kin terms from a kinship terminology viewed as a set of (abstract) symbols along with the special symbol, *Self* (which need not be considered to be a kin term) labeling the concept of self. The entries in the middle right box in Figure 3 are transliterations of the generating kin terms for the Tongan Kinship Terminology (TKT). As noted above, the concept of a relation for kin terms is understood in the context of a symbolic domain as a way to link kin term symbols through taking products of the generating kin terms for the terminology. Recursion in the terminological space will be interpreted as repeated products with the generating kin terms. The structural constraint is specified as a kin term grammar and consists of structural equations and structural rules (to be discussed below).

---

<sup>18</sup> If we include affinal links in genealogical tracing the constraints on admissible paths are more complex and culture specific, which is yet another argument against assuming a genealogical grid as the universal basis for identification of one’s kin.

The core assertion being addressed in the next several sections of this paper is that there is, in fact, a grammar specifiable in terms of structural equations and structural rules that accounts for the structure of kin terms displayed in a kin term map, where a kin term map displays the manner in which the kin terms are conceptually linked through products with the generating kin terms (see Figure 4). The validity of this claim has been demonstrated for the American Kinship Terminology, the Shipibo Kinship Terminology and the Trobriand Kinship Terminology (Read 1984; Read and Behrens 1990). To be demonstrated here is the validity of this assertion for the Tongan terminology.

The kinship space is constructed through instantiation of the symbol strings comprising the terminological space using the relations and symbols from the genealogical space, as will be discussed below (see bottom box, Figure 3). The last entry in the bottom box in Figure 3 connects this construction procedure with the prevalent assumption made in kinship studies that genealogical definitions of kin terms are the primitives of kinship terminologies via genealogical instantiation of the generating kin terms. (Instantiation is not limited to genealogical relations; e.g. kin terms are also instantiated via adoption (Read 2001b).) These definitions are, in fact, predictable and derivable from the terminological space (middle right box in Figure 3) using the instantiation of the generating terms for the terminological space with the generating genealogical relations for the genealogical space (middle left box in Figure 3) (Read 2001). This provides a basis for linking a conceptual system to concrete individuals when the variable, ego, is identified with a specific individual. In other words, Figure 3 provides the conceptual basis for going from the concepts fundamental to any account of culturally constructed kinship, namely the concepts of self, relation and recursion, to the way in which a specific individual implements the conceptual structures making up the kinship space through the actual usage of kin terms.

For the Tongan terminology we have two analytical goals. The first is to demonstrate that the terminology has a structure based on the concepts identified in the box labeled Terminological Space in Figure 3. In so doing we will also demonstrate that the Tongan terminology is a variant on the kind of structure that includes the Trobriand Terminology – which highlights the inadequacy of Murdock’s classification system for terminologies as the Trobriand terminology is not Hawaiian in his classification scheme but the Tongan terminology is Hawaiian. The second goal is to identify the structural and conceptual location of the kin terms *ta’okete* or *tehina* in the terminological space and the manner in which they are concepts fundamental to the generation of the terminological space. The conceptual embedding of these terms in the terminological space, we argue, is central not only to the production of the structure of the Tongan terminology, but provides a “cultural model” for many other domains in Tongan conceptualizations.

#### 4.2 Kin Term Products and Cayley Tables

When Tongans (and others) determine kin relations they need not first refer to a genealogical space and then to kin terms but can determine kin relations directly through kin term calculations. The calculations are of a simple sort: If I (properly) use the kin term *K* to refer to alter<sub>1</sub> and alter<sub>1</sub> properly uses the kin term *L* to refer to alter<sub>2</sub>, what kin term

$M$  may I (properly) use to refer to  $alter_2$ ? For example, in the AKT if  $K$  is the kin term Grandfather and  $L$  is the kin term Brother, then  $M$  is the term Great uncle and this calculation is valid regardless of the genealogical relations among myself,  $alter_1$  and  $alter_2$  (e.g.,  $alter_2$  might be adopted and not the biological brother of  $alter_1$ ). These calculations and their results determine a binary product,  $o$ , over the set of kin terms; thus, continuing the example, Brother  $o$  Grandfather = Great uncle (read “Brother of Grandfather is Great uncle”). The query is also reciprocal for  $alter_2$  with respect to ego.

We may express the results of these calculations through what mathematicians call a Cayley Product Table (named after the 19<sup>th</sup> Century mathematician Arthur Cayley; see Kronenfeld 1980 for an example of a kin product table for the Fanti terminology<sup>19</sup>). A complete Cayley table for the Tongan terminology would list each symbol (i.e., a kin term) as the first element in a row and as the first element in a column of the table and then list in the body of the table the symbol that results from taking the product of the symbols in the row and column intersecting at that position in the table. However, an abbreviated table (see Table 3) can be used in the special case where the terms listed as column headings constitute the generating terms for a terminology constructed from these generating terms. That is, the terms listed in the column headings are a minimal set of kin terms from which every other term can be expressed as some product of the terms listed in these column headings. We may think of taking repeated products with the same kin term as doing the kin product recursively, hence generating other kin terms from the generating terms serves as an instantiation of the recursion concept in the terminological space.

We adjoin the Self symbol to the kinship terminology and define the kin term product of a kin term with the Self symbol to be that kin term. Thus for any kin term,  $K$ , we define  $Self \ o \ K = K \ o \ Self = K$ . Under this product definition for the symbol, Self, Self becomes an identity element for the kin term product.

If the set of kin terms for which a Self symbol is adjoined are all marked with a single gender, say male marked terms (including neutral terms), then the Self symbol can also be sex marked, depending on the terminology. If the procedure of adjoining a sex marked Self symbol is done separately for terms with a male marking and for terms with female marking (as will happen with the Tongan terminology, below), then we would adjoin two Self symbols, one marked as male (MaleSelf) and the other marked as female (FemaleSelf) (see top row of Table 3).

Note that while the concept of self is ontologically prior to the concept of a kinship terminology as shown in Figure 1, there need not be a *kin term* that explicitly represents the self concept. The concept of self is central to a kinship terminology as “self” is defined

---

<sup>19</sup> Kronenfeld compares calculation of relations using kin terms with the explicitly genealogically based rewrite rule/extensionist analysis associated with Lounsbury and concludes that calculations with kin terms “most [sic] accurately represents the way in which Fanti actually compute the denotata of their kin-terminological system” (Kronenfeld 1980: 167). Kronenfeld also observes – in contradiction of the extensionist assumption of rewrite rule analysis -- that one can determine the genealogical referents of terms from the kin term calculations via the genealogical referents of the primary kin terms. But despite these observations, Kronenfeld considers analysis of the calculation of relations to be too particularistic “to use for perceptive cross-cultural comparisons” (1980: 151), as he did not realize there is a logic underlying the calculation of relations using kin terms that allows for insightful, cross-cultural comparisons.

by “other” (and vice versa) and the terminology determines how the category of “other” shall be conceptualized with regard to both what are kin relations and how kin relations structure the category of “other.” No claim is being made that Self becomes a kin term in the American Kinship Terminology, for example, when the symbol, Self, is added to the symbol set of kin terms. Rather, we are simply extending the symbol set in such a manner so as to include the concept of self. The addition of the element Self ensures that the symbol set now has an identity element/focal term under the binary product,  $\circ$ , through incorporating the concept of self. Note that the term, ego, plays a similar role with respect to genealogical relations. Ego is a technical term introduced recently into kinship studies<sup>20</sup> to provide an expression that can represent, in the conceptual structure of genealogical relations, the “beginning point” for genealogical tracing. Genealogical tracing implicitly had the notion of an “ego” even prior to the use of the morpheme “ego.”

We can present the kin term map in the form of a graph by letting the nodes of the graph be the kin terms listed as row headings in the Cayley Table for the terminology and using an arrow to represent taking the product of a kin term with one of the generating terms listed in the column headings (see Figure 4). The tip of the arrow points to the kin term identified through that kin term product. We can use distinctive arrows, one for each generating term, so as to know what kin term product is represented by an arrow. A kin term map for Table 1 is quite complicated as 10 kinds of arrows are needed. Alternatively, we can give a sense of the structure of the terminology by using a more restricted map such as all male marked kin terms (see below).

**Note to Table 3: Tongan Kin Term Products and Kin Terms Predicted From Products of Algebraic Symbols**

---

Note 1: 1<sup>st</sup> row: line 1, algebraic generators; line 2, transliteration; line 3, kin term isomorphic to a generator. 1<sup>st</sup> column: algebraic symbol products; 2<sup>nd</sup> column: isomorphic kin terms. Body of table: Kin terms isomorphic to the algebraic product of column headings x row headings. Body of table is the predicted kin term for the corresponding column and row algebraic product; e.g.  $P (\cong \text{Tamai}) \times G (\cong \text{Ta'e}) = PP$  and Kui corresponds to PP. Thus Kui is the predicted kin term for the kin term product: Tamai of Fa'e. In fact, Tamai of Ta'e is Kui as a kin term product.

Note 2: -M and -F sex markers are added to kin terms when the kin term depends on sex of speaker; e.g. Ta'okete is “O brother” only for a male speaker so the table lists the term Ta'okete-M.

Note 3: A kin term begins with a sex symbol to indicate when the sex of the speaker is necessary; e.g. ♂Tuofefine is “Sister” (ms.).

---

<sup>20</sup> The use of the word, ego, in English writing dates back to 1789 according to the Oxford English Dictionary, 2<sup>nd</sup> Edition.

Algebraic Symbols transliteration Terms	C "Y Brother" Tehina-M	P "Father" Tamai	I Male Self Tuonga'ane	A "Son" Foha	B "O Brother" Ta'okete-M	D "O Sister" Ta'okete-F	i Female Self Tuofefine	G "Mother" Fa'e	H "Y Sister" Tehina-F	E "Daughter" 'Ofefine
H Tehina-F	0	P = Tamai	I = Tuonga'ane	Ei&Ai = Tama	0	i = Tuofefine	H = Tehina-F	G = Fa'e	H = Tehina-F	Ei&Ai = Tama
G Fa'e	0	PP = Kui	IG = Fa'etangata	Tuonga'ane	0	G = Fa'e	G = Fa'e	PP = Kui	G = Fa'e	i = Tuofefine
i Tuofefine	0	P = Tamai	li = Tuonga'ane	Ei&Ai = Tama	0	D = Ta'okete-F	i = Tuofefine	H = Tehina-F	H = Tehina-F	Ei&Ai = Tama
Ei&Ai Tama	Ei&Ai = Tama	0	Ei&Ai = Tama	AA&EE = Mokopuna	Ei&Ai = Tama	Ei&Ai = Tama	Ei&Ai = Tama	i = Tuofefine	Ei&Ai = Tama	AA&EE = Mokopuna
D Ta'okete-F	0	P = Tamai	I = Tuonga'ane	Ei&Ai = Tama	0	D = Ta'okete-F	D = Ta'okete-F	G = Fa'e	i = Tuofefine	Ei&Ai = Tama
B Ta'okete-M	I = Tuonga'ane	P = Tamai	B = Ta'okete-M	A = Foha	B = Ta'okete-M	0	i = Tuofefine	G = Fa'e	0	EI = 'Ofefine
A (= AJ) Foha	A = Foha	I = Tuonga'ane	A = Foha	AA&EE = Mokopuna	A = Foha	0	EI = 'Ofefine	0	0	AA&EE = Mokopuna
I Tuonga'ane	C = Tehina-M	P = Tamai	I = Tuonga'ane	EI = 'Ofefine	B = Ta'okete-M	0	li = Tuofefine	G = Fa'e	0	EI = 'Ofefine
P Tamai	P = Tamai	PP = Kui	P = Tamai	I = Tuonga'ane	P = Tamai	0	iP = Mehekītanga	PP = Kui	0	i = Tuofefine
C Tehina-M	C = Tehina-M	P = Tamai	C = Tehina-M	A = Foha	I = Tuonga'ane	0	i = Tuofefine	G = Fa'e	0	EI = 'Ofefine
PP&GG Kui	PP = Kui	PP = Kui	PP = Kui	P = Tamai	PP = Kui	PP = Kui	PP = Kui	PP = Kui	PP = Kui	iP = Mehekītanga
IG Fa'etangata	IG = Fa'etangata	PP = Kui	IG = Fa'etangata	I = Tuonga'ane	IG = Fa'etangata	0	G = Fa'e	PP = Kui	0	i = Tuofefine
li ♀ Tuonga'ane	li = Tuonga'ane	P = Tamai	li = Tuonga'ane	Ali&Eli = Fakafofuta	li = Tuonga'ane	0	i = Tuofefine	G = Fa'e	0	Ali&Eli = Fakafofuta
AA&EE Mokopuna	AA&EE = Mokopuna	Ei&Ai/A = Tama/Foha	AA&EE = Mokopuna	AA&EE = Mokopuna	AA&EE = Mokopuna	AA&EE = Mokopuna	AA&EE = Mokopuna	Ei&Ai/A = Tama/Foha	AA&EE = Mokopuna	AA&EE = Mokopuna
EI 'Ofefine	0	I = Tuonga'ane	A = Foha	AA&EE = Mokopuna	0	EI = 'Ofefine	EI = 'Ofefine	0	EI = 'Ofefine	AA&EE = Mokopuna
il ♂ Tuofefine	0	P = Tamai	I = Tuonga'ane	Ei&Ai = Tama	0	iI = Tuofefine	iI = Tuofefine	G = Fa'e	iI = Tuofefine	Ei&Ai = Tama
iP Mehekītanga	0	PP = Kui	P = Tamai	I = Tuonga'ane	0	iP = Mehekītanga	iP = Mehekītanga	PP = Kui	iP = Mehekītanga	i = Tuofefine
Ali&Eli Fakafofuta	Ali&Eli = Fakafofuta	li = Tuonga'ane	Ali&Eli = Fakafofuta	AA&EE = Mokopuna	Ali&Eli = Fakafofuta	Ali&Eli = Fakafofuta	Ali&Eli = Fakafofuta	0	Ali&Eli = Fakafofuta	AA&EE = Mokopuna
EiI&AiI 'Ilamutu	EiI&AiI = 'Ilamutu	0	EiI&AiI = 'Ilamutu	AA&EE = Mokopuna	EiI&AiI = 'Ilamutu	EiI&AiI = 'Ilamutu	EiI&AiI = 'Ilamutu	EiI&AiI = 'Ilamutu	EiI&AiI = 'Ilamutu	AA&EE = Mokopuna

### 4.3 Algebraic Analysis

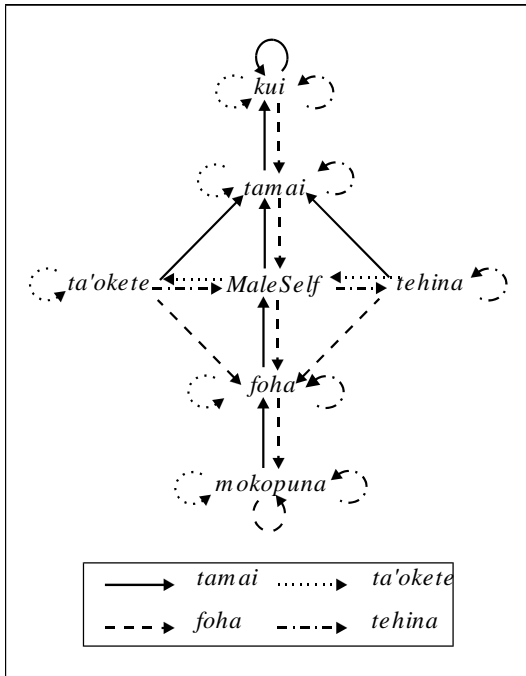

**Figure 4:** Kin term map for male terms.

A semigroup is a structure made up of a set  $S$  of symbols and a binary product,  $\circ$ , defined for all pairs of symbols (that is for  $s, t \in S$  (read, “for  $s, t$  in the set  $S$ ”) there is a symbol  $u \in S$  with  $s \circ t = u$ ), with the stipulation that  $\circ$  is an associative product (that is, for  $s, t, u \in S$ ,  $s \circ (t \circ u) = (s \circ t) \circ u$ ; i.e. products are unchanged by the sequence in which products are computed). The counting numbers with the binary product, multiplication, is an example of a semigroup. The initial goal of the algebraic analysis is to determine whether or not the collection of kin terms making up a terminology has a structure embedded within it – a simplified kin term map -- that

The algebraic analysis is aimed at representing the kin term map in the form of an algebraic structure known as a semigroup, if possible. We stress the “if possible” since not all structures can be isomorphically represented in the form of an algebraic structure. In other words, the claim that the kin term map can be represented isomorphically as an algebraic structure is falsifiable and the claim would be falsified if there is no algebraic structure isomorphic to the kin term map. From the perspective of the “received view” that kin terms are added to a terminology for reasons exogenous to the terminology per se, there is no reason to expect that the collection of kin terms will have an algebraic structure.<sup>21</sup>

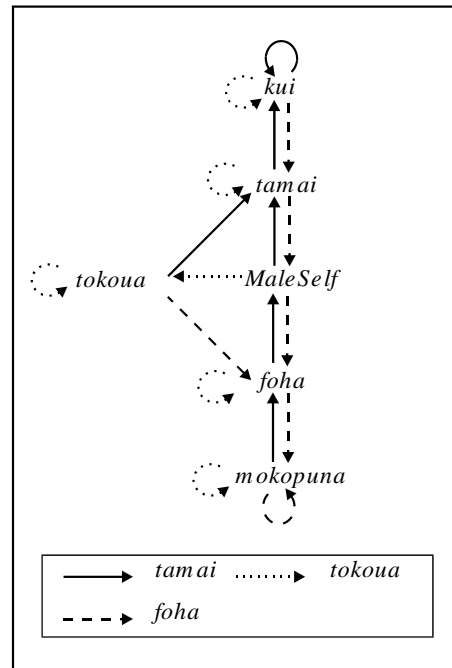

**Figure 5:** Kin term map with *tokoua* ‘same sex sibling’.

<sup>21</sup> The falsifiability of the claim that the kin term map has an algebraic structure contrasts sharply with descriptive methods such as componential analysis and rewrite rules as the latter simply provide descriptions, hence there is nothing to be falsified.

can be generated from a small set of atomic kin terms and certain structural equations relating to the products of kin terms. An example of a structural equation would be, say, an equation that indicates the consequence of taking the product of a sibling term with a parental term as occurs in the expression (using transliterated kin terms): ‘father’ o ‘older brother’ = ‘father’ (read: ‘father’ of ‘older brother’ is ‘father’).

The algebraic analysis proceeds by first simplifying the kin term map, next finding an (isomorphic) algebraic representation of the simplified kin term map, if any, and then adding to the algebraic representation the structural aspects of the full kin term map removed through the simplification. Isomorphism between the full kin term map and this algebraic construction demonstrates that the kinship term structure can be generated axiomatically. This construction process is potentially falsifiable as there are structures that cannot be represented isomorphically in this manner. Whether there are kin terminology structures that cannot be so represented is an open, empirical, question.

From the algebraic representation of the structure of the kin term map a set of predicted genealogical definitions of kin terms can be constructed. The predicted definitions are formed by first mapping the generating kin terms onto the genealogical space and secondly by determining the portion of the genealogical space that would be covered by a kin term based upon the mapping of the generating kin terms onto the genealogical space, using the algebraic representation of the kin term map structure.

Underlying the construction of a structure that may be isomorphic to the kin term map is a general procedure for introducing five primary structural aspects of a terminology: (1) a structure based on products of kin terms (transitivity of kinship relations expressed using kin terms), (2) reciprocity of kin terms as a structural property (symmetry of kinship relations expressed using kin terms), (3) the sex marking of kin terms, (4) introduction of affinal kin terms and (5) local modification of the kin term structure (such as logic underlying the “ith cousin j-times removed” terms in the AKT).

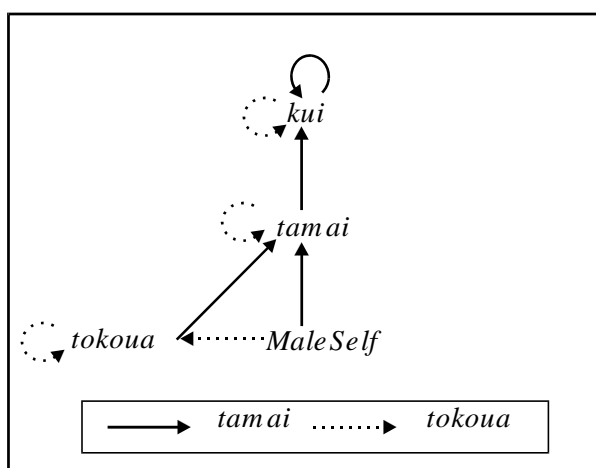

Figure 6: Kin term map with descending terms removed.

#### 4.3.1 Simplification of a Kin Term Map.

We begin by structurally simplifying the kin term map to arrive at a core structure from which we begin the algebraic construction. A kin term map is simplified by first restricting the map to consanguineal terms. It can then be simplified further by restricting the map for the consanguineal terms to terms of a single sex (including neutral terms since a neutral term can be of either sex) so as to have the terms used by persons of that sex (see Figure 4).<sup>22</sup> Next, we remove reciprocal terms. For the TKT, we first

<sup>22</sup> Some terminologies are simplified by considering neutral, “covering” kin terms; e.g., the terms Parent, Child, Grandparent, Grandchild, etc. in the AKT.

remove the reciprocal attributes older/younger by removing the terms *ta'okete* 'older brother' and *tehina* 'younger brother' and replacing them by *tokoua* 'same sex sibling,' since *tokoua* does not have the older/younger attributes (see Figure 5). Then we remove the reciprocal of *tamai* 'father,' namely *foha* 'son' (see Figure 6). Finally we remove the ascending structure and arrive at a simplified kin term map for the TKT based on a single kin term, *tokoua* (see Figure 7).

Note that the kin term *tuonga'ane*, which has transliteration 'brother (f.s.),' is not included in Figure 4 as it is properly used by a female speaker, hence is not a term from the viewpoint of a male speaker. In addition, the male term, *fa'etangata* 'older brother' of 'mother,' is excluded at this stage in the analysis since it is isolated from the male marked kin terms in Figure 4 and so is not part of the structure shown in Figure 4. This term will be introduced into the structure as the analysis proceeds.

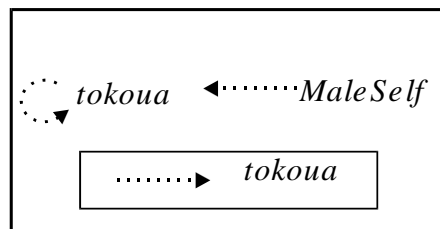

**Figure 7:** Kin term map with ascending terms removed.

### 4.3.2 Generating Term and an Identity Operator

The generating kin term for the simplified Tongan structure shown in Figure 7 is the kin term *tokoua* 'same sex sibling'. We have adjoined the symbol *MaleSelf* to the male marked terms (see Figures 4 – 7) to provide a symbol that will correspond to the identity element in the algebra.<sup>23</sup> The *MaleSelf* symbol, when instantiated, can be thought of as an operator that identifies the reference person for the topic at hand. Thus if the topic has to do with genealogies, *MaleSelf* will be instantiated as "male ego" and the latter will be the reference point for the genealogy. Hence when male ego is identified with an actual person, male ego is replaced by the person whose genealogy is being constructed. More formally, if we let *P* be a set of persons, then *MaleSelf*: *P* → *x*, where *x* is the male person for the topic of discussion.

<sup>23</sup> We can extend the kin term product to include products using the *MaleSelf* symbol in the following manner. First, for *MaleSelf* of *MaleSelf*, suppose ego refers to alter<sub>1</sub> as *MaleSelf* and alter<sub>1</sub> refers to alter<sub>2</sub> as *MaleSelf*. Then "ego refers to alter<sub>1</sub> as *MaleSelf*" implies that ego = alter<sub>1</sub>. Hence the statement "alter<sub>1</sub> refers to alter<sub>2</sub> as *MaleSelf*" can be rewritten "ego refers to alter<sub>2</sub> as *MaleSelf*" and so ego = alter<sub>2</sub>. Since ego refers to ego as *MaleSelf*, it follows that *MaleSelf* of *MaleSelf* is *MaleSelf*.

Next, if a male ego refers to alter<sub>1</sub> by the kin term *K* and alter<sub>1</sub> refers to alter<sub>2</sub> by *Male Self*, then alter<sub>2</sub> is, in fact, alter<sub>1</sub> and since a male ego refers to alter<sub>1</sub> = alter<sub>2</sub> by the kin term *K*, then we have *Male Self* of *K* is *K*.

Similarly, if ego refers to alter<sub>1</sub> by *Male Self* and alter<sub>1</sub> refers to alter<sub>2</sub> by *K*, then ego = alter<sub>1</sub>, and since alter<sub>1</sub> refers to alter<sub>2</sub> by *K*, then male ego refers to alter<sub>2</sub> by *K*. Hence *K* of *Male Self* = *K*.

Next we note that a symbol *I* with the property that taking products of any symbol, *S*, with *I* always yields the original symbol, *S*, (that is, *IS* = *SI* = *S* for all symbols, *S*) is known as an *identity element*. By the above extension of the kin term product to the symbol *Male Self*, *Male Self*, is an identity element for the set of male kin terms.

### 4.3.3 Construction of an Algebraic Model: Initial Generating Element

We begin the algebraic construction by introducing an algebraic symbol corresponding to each kin term that is a generating term for the simplified kin term map. It is convenient to use a symbol label that reflects the anticipated correspondence of the symbol with a kin term. We then take all possible products using the algebraic symbol(s) that have been introduced. Next, we add structural equations that give a symbol the structural property corresponding to the anticipated correspondence of the algebraic symbol with a kin term concept. These equations may reduce certain of the products to simpler expressions. As the algebraic construction proceeds we introduce additional symbols corresponding to the other generating elements shown in the kin term map for the terminology.

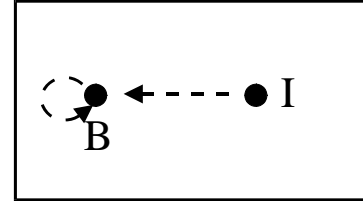

**Figure 8:** Algebra with sibling generating element.

The structural equations to be satisfied when taking products of generating terms are of two kinds. The first set of structural equations is responsible for (1) giving each generating element its defining structural characteristics and (2) expressing the structural consequence of taking products of one generating element with another generating element. The second set of structural equations gives the structure of the kinship terminology its overall form.

For the TKT we begin with the symbols B and I, where I will be an identity element for the algebra and B will have the structural properties of a sibling term. A sibling term such as ‘brother’ satisfies the property that ‘brother’ of ‘brother’ is ‘brother.’ Thus the first set of equations for the algebra will be: ‘brother’ of ‘brother’ is ‘brother’ (Sibling Structural Equation).

Corresponding to this kin term property is the algebraic structural equation:

$$BB = B. \tag{1}$$

The algebraic structure generated by this element and structural equation is shown in Figure 8. Clearly this structure is isomorphic with the kin term map shown in Figure 7.

### 4.3.4 Ascending Structure

Next we expand this structure to an ascending structure by introducing the symbol, F, with anticipated correspondence with the kin term *tamai* ‘father.’ Consider the interpretation of ‘father’ as an ascending kin term. A property that an *ascending term* satisfies, from a structural viewpoint, is that products of the term with itself can be repeated indefinitely. For this property no structural equation is needed. Note that Equation (1) distinguishes a sibling term from an ascending term. When we add the element F to the

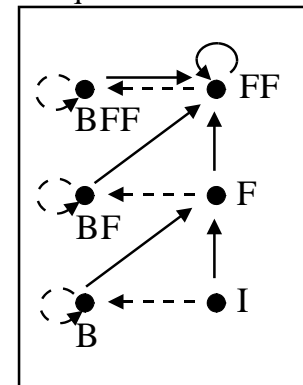

**Figure 9:** Algebra with sibling and father generating elements.

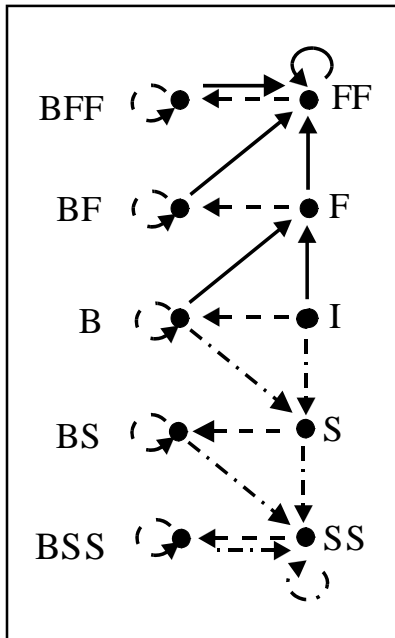

Figure 10: Structure with reciprocity of element added.

algebra we need to determine what structural equations define the product between the symbols F and B. For a ‘sibling’ term and a ‘father’ term we have the structural property that

‘father’ of ‘brother’ is ‘father’ (Father Structural equation).

Corresponding to this kin term equation we have the algebraic structural equation:

$$FB = F.$$

#### 4.3.4.1 Structural Form: Ascending Structure

The overall form of the ascending structure is determined by whether or not products of the ascending terms continue to yield new terms; that is, products that cannot be reduced to other kin terms. In the AKT, for example, we have the sequence Parent, Grandparent, Great-grandparent, ... that, in principle, extends indefinitely. The alternative is that products of ascending terms, at some point, do not give rise to new products or are not defined.

For the Tongan terminology we have the sequence *tamai*, *kui* and the term *kui* is simply repeated when taking products with the term *tamai*. Thus for the Tongan terminology the second set of equations for the ascending structure consists of the equation:

*tamai* of *tamai* of *tamai* is *tamai* of *tamai* is *kui*,

or in transliterated form,

‘father’ of ‘father’ of ‘father’ is ‘father’ of ‘father’ is ‘grandfather’ (Closure equation for kin term products),

We may express this equation using algebra symbols via the equation

$$FFF = FF. \tag{3}$$

At this stage in the algebraic representation, BF (‘brother’ of ‘father’) is still a new, compound algebra symbol since there is, as yet, no equation in the algebra that would reduce this product to a simpler form. The structure produced by equations (1) – (3) is shown in Figure 9. We will interpret this structure as representing the structure for the ascending male terms in the Tongan terminology.

### 4.3.5 Descending Structure

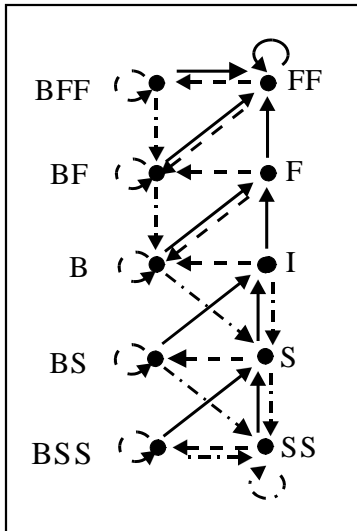

**Figure 11:** Structure with descending elements added.

We construct the descending structure by making an isomorphic copy of the ascending structure. The isomorphic copy provides the structure for the descending structure and initially has the same morphological form as the ascending structure. In the isomorphic copy we introduce a element S as the element isomorphic to F and so we have the isomorphic correspondence  $S \leftrightarrow F$ . The element B will remain the same and the element, I, corresponding to MaleSelf will remain the same. The element I will thus be the identity element for both the ascending structure and the descending structure.

We introduce the equations isomorphic to the structural equations (2) – (3):

$$SB = S \text{ (Son Structural Equation)}$$

and

$$SSS = SS \text{ (Product Closure Equation for S)}.$$

We now have a structure of ascending elements and a structure of descending elements ‘linked’ by the identity symbol, I, and the sibling element, B (see Figure 10). The structure shown in Figure 10 must be expanded so as to include all possible products using the symbols F, B, and S in order for the algebraic structure to be complete. For these products we have the equation:

$$SF = B \tag{4}$$

by virtue of the notion that the kin term product ‘son’ of ‘father’ yields a sibling kin term, namely B. Equation (4) implies that  $SFF = BF$ .

The product  $SBF = (SB)F = SF = B$ , thus we have the equation:

$$SBF = B. \tag{5}$$

By a similar argument,  $SBFF = BF$ .

The implication of these equations for the ascending/descending structure can be seen in the upper part of Figure 11. The lower part of Figure 11 also takes into account reciprocity between the algebra symbols F and S (next section).

#### 4.3.5.1 Reciprocal Elements: F and S

We want the elements F and S to be reciprocal. Structural equations that make the algebra symbols X and Y into reciprocal elements are of the form:

$$XY = I$$

This equation is motivated by the observation that if a (male) ego refers to a (male) alter by the kin term K then the kin term K’ used by alter to refer to ego is the reciprocal of the kin term K, hence  $KK' = \text{MaleSelf}$ .

For the elements F and S we introduce the equation

$$FS = I. \tag{6}$$

The algebraic structure corresponding to Equations 4 – 6 is shown in Figure 11.

**4.3.5.2 Reciprocal Elements: B → B+ and B-**

The reciprocal of the element B should be a symbol X with the property that BX = I or XB = I. This poses a dilemma as the candidate for a reciprocal for B appears to be B (since ‘brother’ is a self-reciprocal concept), hence we should introduce the equation BB = I. But BB = B and this would imply B = BB = I. The solution to the dilemma is to bifurcate the symbol B into the pair of symbols, B+ and B-, and to introduce the sibling equations

$$B+B+ = B+ \tag{7}$$

and

$$B-B- = B- \tag{7'}$$

and the reciprocal equations

$$B+B- = I \tag{8}$$

and

$$B-B+ = I. \tag{8'}$$

The symbols B+ and B- will correspond to the terms *ta’okete* and *tehina*, respectively.

In terms of the structure given in Figure 11, we replace the element B by the element B+ and then construct the reciprocal element for B+ and its structural implications by taking an isomorphic copy of the modified structure shown in Figure 11, keeping fixed F, S and I, and adding a new element, B- with the isomorphic correspondence B+ ↔ B-. Finally, we introduce equations (7) – (8’) into the algebra.

Equation (8) implies:

$$FB- = F \text{ (Father Structural Equation) (2')} \tag{9}$$

since B+B- = I implies F = FI = F(B+B-) = (FB+)B- = FB-. Equation (2), FB+ = F, (with B replaced by B+ in Equation (2)), has isomorphic copy the equation

$$SB- = S \tag{9}$$

And Equation (4) (SF = B+ after B has been replaced by B+) has reciprocal equation

$$SF = B-. \tag{10}$$

The algebraic structure corresponding to this isomorphic construction is shown in Figure 12.

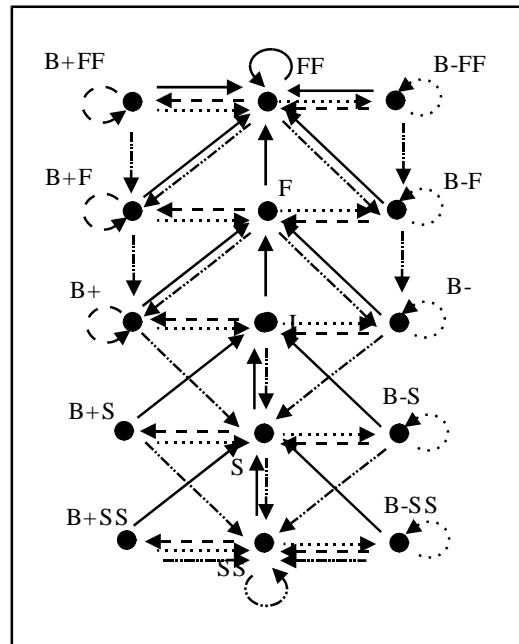

**Figure 12:** Algebra with reciprocal ‘sibling’ elements.

**4.3.5.3 Reciprocal Equations**

A general property of reciprocal terms as they occur in terminologies is that if  $XY = Z$  is a structural equation for the terminology then the reciprocal equation  $(XY)^r = Y^rX^r = Z^r$  is a structural equation for the terminology. For the equations in 4.3.4.1, the reciprocal equation for equation (1) is equation (1'), the reciprocal equation for (3) is (3'), and (5), (6), and (7) are self-reciprocal equations. Equations (2) and (2') have for their reciprocal equations:

$$B-S = S \tag{2''}$$

$$B+S = S, \tag{2'''}$$

respectively.

These equations have genealogical interpretation: genealogical younger brother of genealogical son is genealogical son and genealogical older brother of genealogical son is genealogical son. Finally we include the reciprocal equations for the remaining two equations, (2') ( $SB+ = S$ ) and (9) ( $SB- = S$ ):

$$B-F = F \tag{2*}$$

$$B+F = F. \tag{9*}$$

Remarkably, we have introduced precisely the fundamental equations for a classificatory terminology simply by following a general procedure for the construction of a kinship terminology. This general procedure for generating a terminology underlies both

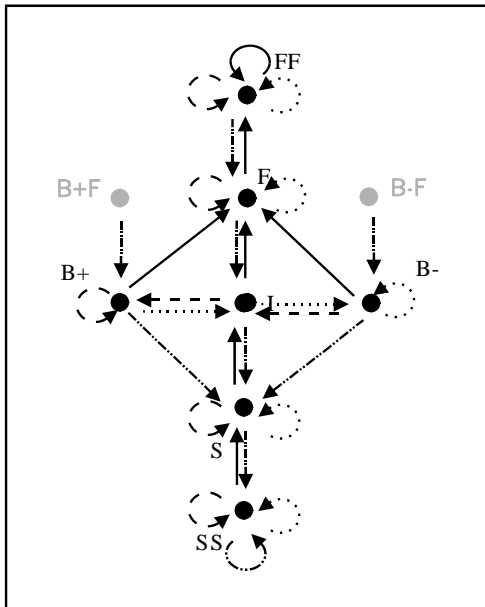

**Figure 13:** Reduced algebraic structure.

descriptive and classificatory terminologies (see Read and Behrens 1990). The construction thus implies that the classificatory aspect of the Tongan terminology (and also for other classificatory terminologies) derives logically from a general ontology for the construction of a kinship terminology and the fact that a sibling term is one of the atomic terms in the kinship terminology. This contrasts with the construction of a descriptive terminology where the construction is based on a single ascending term and a sibling term such as Brother in the American Kinship Terminology is a compound term constructed from taking products of the Mother or Father term with the Son term.

We cannot emphasize too strongly the importance of this result for understanding not only the structure of terminologies such as the Tongan terminology, but also the implications it has for the centrality of the sibling relation in

Tongan behavior and cultural representations. The centrality of the sibling relation in Tongan life reflects the centrality of the sibling element as an atomic element in the construction of the Tongan terminology.

The isomorphic construction removes the potential ambiguity of Equations (4)  $SF = B+$  and Equation (10)  $SF = B-$  via the fact these two products imply, respectively,  $I = B-B+ = B-SF = (B-S)F = SF$  and  $I = B+B- = B+SF = (B+S)F = SF$  and so in the structure obtained from making an isomorphic copy of the structure shown in Figure 6, we define  $SF = I$ . This yields the male structure for the TKT (see Figure 13).

#### **4.3.6 Male Structure**

We have now constructed the structure for the male marked kin terms. The salient features are:

Generating Elements: F, B+

Reciprocal Elements: S, B-

Identity Element: I

Structural Equations:

$$B+B+ = B+$$

$$FB+ = F$$

$$FB- = F$$

$$FFF = FF$$

Isomorphic Structural Equations:

$$B-B- = B-$$

$$SB- = S$$

$$SB+ = S$$

$$SSS = SS$$

Reciprocal Definition Equations

$$FS = I$$

$$SF = I$$

$$B+B- = I$$

$$B-B+ = I$$

Reciprocal Equations (not already included above)

$$B-S = S$$

$$B+S = S$$

Classificatory Equations

$$B+F = F$$

$$B-F = F$$

The structure corresponding to these equations is shown in Figure 13.

Note in Figure 13 the two nodes, B+F and B-F, in gray. As nodes these two positions have been transformed into the “F” node since  $B+F = F = B-F$ . But the S arrows from these two nodes to B+ and B, respectively, have not been transformed. Hence it follows that B+F and B-F are unlabeled, implicit nodes due to their transformation into the F node, yet the mapping of these two implicit nodes to B+ and B- is still part of the structure. Consequently the algebraic structure implies that when the kin terms are instantiated using

the genealogical space, the instantiation  $B+F \rightarrow \{\text{genealogical father's genealogical older brother}\}$  should have the property that (genealogical father's genealogical older brother)'s genealogical son will be genealogical older brother (since  $SB+F = B+$ ) and similarly (genealogical mother's genealogical older sister)'s genealogical son will be genealogical older brother. Similar arguments apply to  $B-F$  and  $Z-M$ . In fact this interpretation is valid as can be seen in Table 4.

**Table 4: 'Older/Younger' Sibling Terms**

	man speaking	woman speaking
<i>ta'okete</i>	b+, fb+s, mz+s	z+, fb+d, mz+d
<i>Tehina</i>	b-, fb-s, mz-s	z-, fb-d. mz-d

\* modified from Table 1 (Biersack 1982)

The polysemic aspect of *ta'okete* and *tehina* implies that the transliteration 'older same sex sibling' and 'younger same sex sibling' only partially expresses the semantic meaning of these two terms. The attributes, older/younger, imply relative age of alter with respect to speaker, but the offspring of, for example, 'older brother' of 'father' may be younger than speaker yet is still called *ta'okete*. This suggests that attributes such as ascending/descending or superior/inferior more precisely capture the "meaning" of the pair of terms *ta'okete/tehina* than does older/younger. Note that the descriptive information provided in Table 4 is simply taken as a descriptive fact of the TKT when viewed from a genealogical perspective. The algebraic construction makes evident the structural basis for the factual information provided in Table 4, hence the basis for the different behavior ego has towards genealogical older/younger siblings versus genealogical parallel cousins even though these two sets of genealogical relations are not differentiated terminologically (see discussion by Biersack 1982 regarding ego's differential behavior based on the terminological distinction ego's parents makes between the two kinds of genealogical relations).

#### **4.3.7 Female Structure**

We introduce female marked elements corresponding to the male marked elements by making an isomorphic copy of the male structure summarized in 4.3.6. Under this isomorphism new female marked symbols,  $M$ ,  $Z+$ ,  $Z-$ ,  $D$  and  $i$ , are introduced corresponding to each of the male marked symbols:  $M \leftrightarrow F$ ,  $Z+ \leftrightarrow B+$ ,  $Z- \leftrightarrow B-$ ,  $D \leftrightarrow S$  and  $i \leftrightarrow I$ . This yields a structure of female marked elements defined by:

Generating Elements:  $M$ ,  $Z+$

Reciprocal Elements:  $D$ ,  $Z-$

Identity Element:  $i$

Structural Equations:

$$\begin{aligned} Z+Z+ &= Z+ \\ MZ+ &= M \\ MZ- &= M \\ MMM &= MM \end{aligned}$$

Isomorphic Structural Equations:

$$\begin{aligned} Z-Z- &= Z- \\ SZ- &= S \\ SZ+ &= S \\ SSS &= SS \end{aligned}$$

Reciprocal Definition Equations

$$\begin{aligned} MS &= I \\ SM &= i \\ Z+Z- &= i \\ Z-Z+ &= i \end{aligned}$$

Reciprocal Equations (not already included above)

$$\begin{aligned} Z-S &= S \\ Z+S &= S \end{aligned}$$

Classificatory equations

$$\begin{aligned} Z+M &= M \\ Z-M &= M \end{aligned}$$

#### 4.3.8 Joint Male Structure and Female Structure

At this point we have two unconnected structures since we have introduced new elements {M, Z+, Z-, D, i} for the isomorphic copy of Figure 13 without any overlap with the

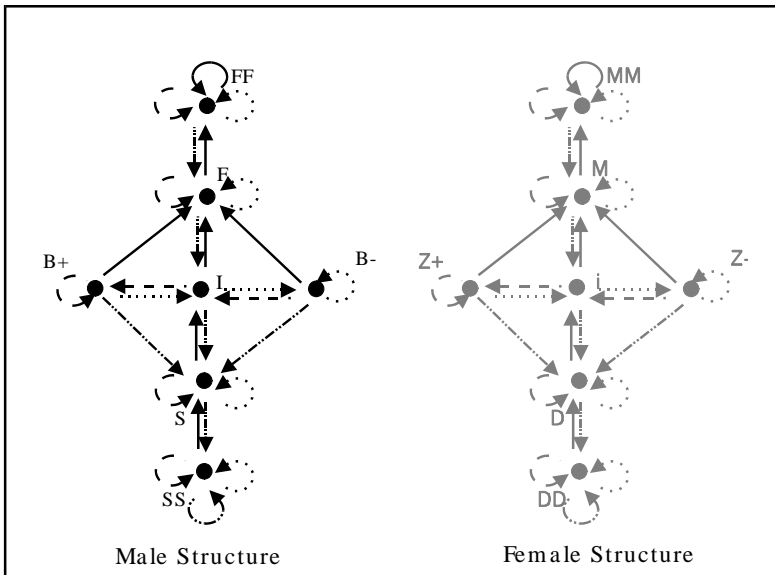

**Figure 14:** Algebra of male elements and algebra of female elements.

generating elements {F, B+, B-, S, I} for the male marked elements (see Figure 14). There is no way to compute the products of elements from the male structure with elements from the female structure until we determine a linkage between the two structures. This contrasts with the isomorphic copy of the ascending elements where the element, I, was the same in both the structure of ascending elements and the structure of descending elements and products of ascending and descending

elements could be computed by reference to this single structure. We now consider how the male structure and the female structure are linked conceptually and structurally to make a single structure in which products of male marked elements with female marked elements may be computed.

#### 4.3.8.1 Conceptual Linkage: Sex Marked Identity Elements

The culturally formulated means for conceptually connecting the two structures together is ingenious. Consider the two symbols, I (MaleSelf) and i (FemaleSelf). If I is instantiated with a male person, then what female should be used to instantiate the i symbol? That is, who should be a female ego corresponding to a male ego? The solution that has been introduced into the classificatory terminologies is to instantiate female ego with male ego's genealogical sister and if i has been instantiated with female ego, then instantiate I with female ego's genealogical brother. Under this instantiation it follows that the symbol I corresponds to a kin term from the perspective of a female ego, namely I corresponds to the kin term 'brother (f.s)', and similarly from the perspective of a male ego the symbol i corresponds to the kin term 'sister (m.s.)'! Consequently, at the surface level of kin terms we find the Tongan terms *tuonga'ane* 'brother' for a female speaker and *tuofefine* 'sister' for a male speaker, yet at a deeper level the term *tuonga'ane* is the label used by a female person for the element I, with the latter an element that does not have a semantic label in the structure of male elements, and similarly for i and the term *tuofefine*. Thus these two terms, *tuonga'ane* and *tuofefine*, play a dual role: on the one hand, they mark the position at which an ego will be located (male ego at the *tuonga'ane* position, female ego at the *tuofefine* position) and on the other hand they provide the structural nodes for the kin terms to be used by a male ego for a female ego, who is his genealogical sister, and vice-versa. Consequently, from the viewpoint of a male speaker, he has a *ta'okete* 'older brother' or a *tehina* 'younger brother' and he has a *tuofefine* 'sister' but he does not have a *tuonga'ane* 'brother;' similarly for a female speaker, she has a *ta'okete* 'older sister,' a *tehina* 'younger sister' and a *tuonga'ane* 'brother' but she does not have a *tuofefine* 'sister.' This is a very ingenious solution to the problem of conceptually integrating together two distinct structures: a structure of male terms and a structure of female terms and it also accounts for the pattern in which it is only the 'same sex sibling' term that has the attributes older and younger.

Although the element I is an identity element in the structure of male terms (left side of Figure 14) and the element i is an identity element in the structure of female terms (right side of Figure 14), these elements lose their status as identity elements when we form the structure containing both the male and the female structures.<sup>24</sup> Hence products using elements I and i with elements that have the opposite sex marking, including the products Ii or iI, will not simplify according to the equations for identity elements. Instead, the products Ii and iI become new elements in the algebra. These two products correspond to *tuonga'ane* (f.s.) and *tuofefine* (m.s.) with instantiations 'brother of a female self' and 'sister of a male self,' respectively.

---

<sup>24</sup> An algebra can contain at most one identity element. If I and i are both identity elements, then  $I = Ii = i$ .

**4.3.8.2 Structural Linkage: ‘Older Sibling’ and ‘Younger Sibling’**

Consider the algebra symbols I, B+ and B- from the male structure and the elements i, Z+ and Z- from the female structure. The two elements I, and i correspond to the kin terms *tuonga'ane* and *tuofefine*, respectively. If the two algebra symbols B+ and Z+ are made equivalent (see oval in upper part of Figure 15), and similarly B- and Z-, are made equivalent, then we have a single older node and a single ‘younger’ node. These two combined nodes are each not sex marked and structurally link the male structure and the female structure together. The combined node, call it B+&Z+, is labeled with the kin term *ta'okete* (‘older same sex sibling’) and the other combined node, B-&Z-, is labeled with the kin term *tehina* (‘younger same sex sibling’) under the isomorphism between the atomic algebra symbols and atomic kin terms.

**4.3.9 Implications of the Structural Linkage for Products with ‘Son’ and ‘Daughter’**

A number of important structural consequences for the Tongan terminology with regard to terms for genealogical children of ego and ego’s genealogical sibling arise from the fact that I, i, Ii and iI are distinct elements (see top part of Figure 16, expanded from Figure 15). Consider the products with S (‘son’) and D (‘daughter’) in the algebraic structure. For the nodes iI and Ii these products yield the nodes (1) SiI and DiI (that is, the algebra symbol corresponding to the kin term for the genealogical son or daughter of a woman who is the genealogical sister of a male ego) and (2) SIi and DIi (that is, the algebra symbol corresponding to the kin term for the genealogical son or daughter of a man who is the genealogical brother of a female ego), respectively. Products with the two nodes, I and i, yield the nodes (3) SI and DI (that is, the algebra symbol corresponding to kin term for the genealogical son or daughter of a male ego) and (4) Si and Di (that is, the algebra symbol corresponding to kin term for the genealogical son or daughter of a female ego) as new, distinct nodes in the algebra.

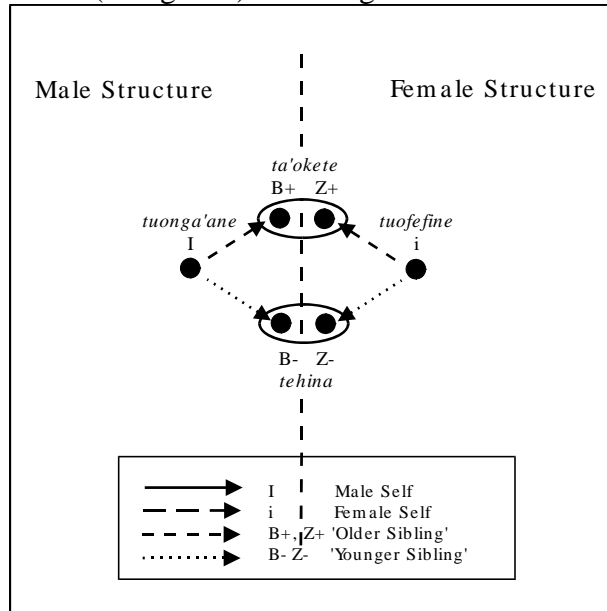

**Figure 15:** Structure for ‘older sibling’ and ‘younger sibling’ elements.

Of these four pairs of products using S and D, each of the pairs of products except SI and DI becomes a single node without sex marking and each of these nodes is mapped to a different kin term (see Figure 16, bottom part of graph). Thus, the kin terms *‘ilamutu* and *fakafotu* correspond to the products  $SiI = DiI = SiI \& DiI$  (‘child’ of ‘sister’ of MaleSelf)

and  $SI = DI = SI \& DI$  ('child' of 'brother' of FemaleSelf), respectively (see Figure 16) and the kin term, *tama* ('child' of FemaleSelf) corresponds to the products  $SI = DI = SI \& DI$  ('child' of FemaleSelf).

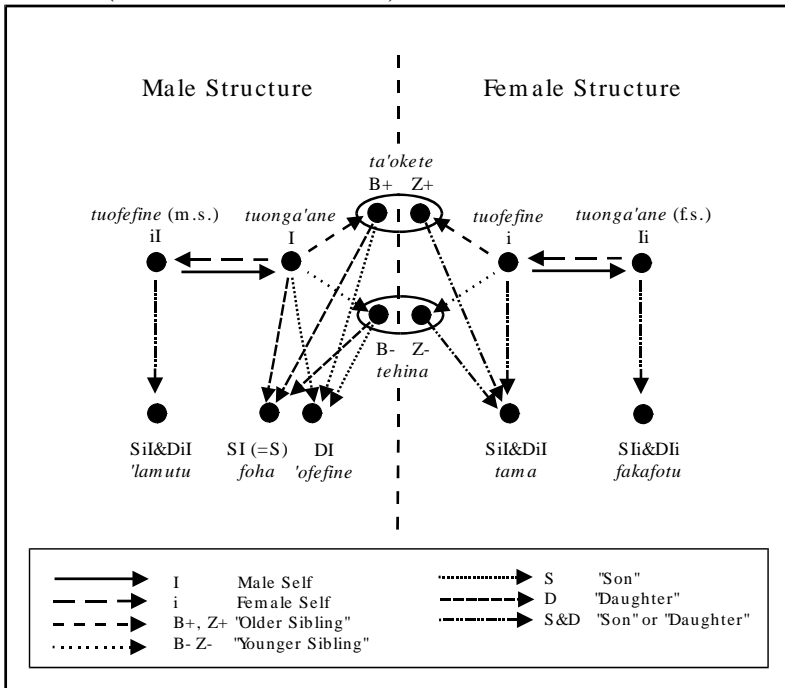

Figure 16: Structure for products of 'son' and 'daughter' elements with 'sibling' elements.

In contrast, the nodes  $SI (= S)$  and  $DI$  ('son' of MaleSelf and 'daughter' of MaleSelf) correspond to different kin terms; namely, *foha* (with instantiation genealogical son, m.s.) and 'ofefine (with instantiation genealogical daughter, m.s.). This can be interpreted as a structural means to embed the generating elements, S and D, into the terminology. If the nodes  $SI$  and  $DI$  were also made into a single node, then the kin terminology would have a 'child' term but no overt term for 'son' or 'daughter' even

though these two terms are part of the generating set for the algebra. Keeping the terms  $SI$  and  $DI$  distinct, then, appears to be a way to explicitly imbed the generating elements S and D into the kin term structure and has implications for the pattern of inheritance in Tongan society (discussed below)

As a consequence, the Tongan terminology has the kin terms *foha* and 'ofefine—but only for a male ego. In contrast a female has only the kin term, *tama* ('child' of FemaleSelf).<sup>25</sup> The fact that it is the element I (MaleSelf) for which the products with S and D keep their sex distinction suggests a "male bias" in the terminology since, from a structural viewpoint, the structure is otherwise symmetric with regard to the male structure and the female structure.

#### 4.3.10 Structural Implications of the Term Tokoua

In Section 3 we noted the term *tokoua* appears to be a central term in the kinship terminology, yet in the final algebraic structure there is no element corresponding to this

<sup>25</sup> Biersack (1982) lists *fefine* as an alternative term for *tama*, the term used by female ego for her child, regardless of sex. Hence the terminology appears to be symmetrical with respect to keeping the products  $SI$ ,  $Si$ ,  $DI$  and  $Di$  distinct, but asymmetrical with the property that the term *tama* is also used as a cover term for both  $Si$  and  $Di$  but no term is used as a cover term for  $SI$  and  $DI$ .

term. Rather than arising from the algebraic construction, the term *tokoua* with its transliteration ‘same sex sibling’ appears to play an ontologically prior role as the label for the concept of a sibling relation fundamental to the Tongan terminology as discussed above in section 4.3.1 – 4.3.3.

We can illustrate the structural position of *tokoua* by considering it to be a concept lying above the sibling plane as shown in Figure 17. Within the plane we have two divisions: horizontally — male/female and vertically — older/younger. The horizontal division arises from the pair of algebra symbols I and i that correspond to the terms *tuonga'ane* and *tuofefine*, respectively. The vertical division arises from the bifurcation of *tokoua* into two sibling terms with the attributes that can be transliterated as older/younger.

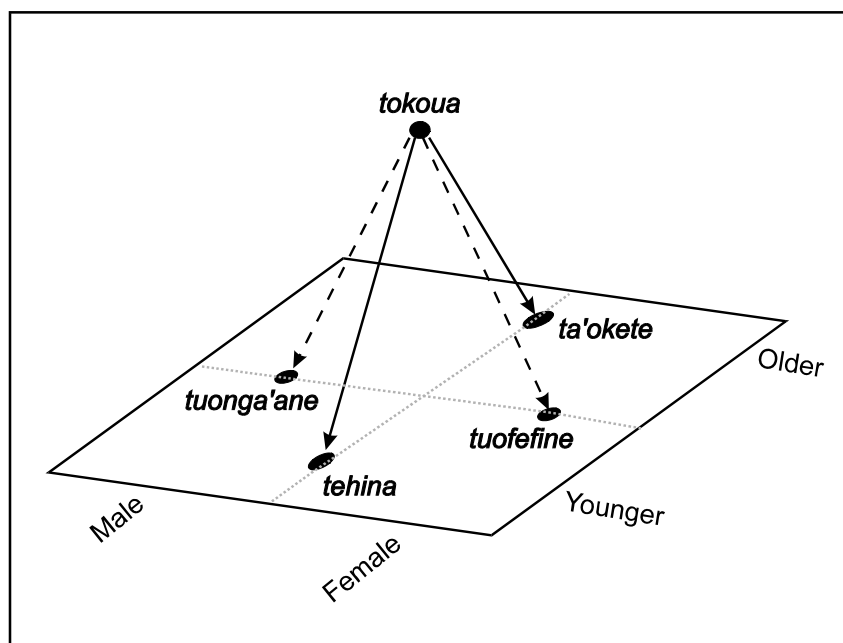

Thus structurally the term *tokoua* represents a primitive concept (‘sibling’) to which the pair of ‘opposite sex sibling’ terms *tuonga'ane* and *tuofefine* are linked through the associated identity symbols, MaleSelf (see Figures 7 and 8) and FemaleSelf (see Figure 14), that are initially unlabeled and then become labeled as a conceptual means to

join together the male structure and the female structure for the purposes of kin term computations (see Figure 15). The derived sibling concepts *ta'okete* ‘older (same sex) sibling’/ *tehina* ‘younger (same sex) sibling’ also arise from the term *tokoua*. *Tokoua* has the structural property of first giving rise to a pair of ‘same sex sibling terms’ with +/- marking in the structure of male terms (see Figure 12) and then to an isomorphic pair of ‘same sex sibling terms’ with +/- marking in the structure of female terms (see Figure 14), and finally to identification of the two + marked terms and of the two – marked terms so as to form a single pair of ‘same sex’ terms *ta'okete/tehina* with +/- marking (see Figure 15). *Tokoua* thus has structural status as the non-sex marked and non-relative age marked sibling term for the terminology as a whole from which one arrives at the two relative age marked terms and the two gender marked terms in the sibling plane. The English word ‘sibling,’ however, has connotations that are not applicable to the Tongan concept of *tokoua*, hence the transliteration ‘same sex sibling,’ which reflects the manner in which the pair of terms *ta'okete/tehina* are constructed from the term *tokoua*.

#### 4.3.11 Cross Products of Male Marked and Female Marked Algebra symbols

The remaining part of the algebraic construction consists of working out the cross products between the elements in the Male Structure and the elements in the Female Structure. This entails adding equations that take into account the sex marking of algebra symbols. The diagram at this point becomes overwhelmed with arrows due to the fact that there are ten generating elements: F, M, B+, B-, Z+, Z-, S, D, I and i. The structure of the algebra can be displayed, instead, in the form of an algebra Cayley Table in parallel with the kin term Cayley Table used to display the structure of kin term products (see Table 3). When these two Cayley Tables are compared we find that they are isomorphic.<sup>26</sup> The isomorphism is shown in Table 3.

In Table 3 the algebra symbols and their correspondence with kin terms are displayed in the row and column headings in Table 3 (compare the 1<sup>st</sup> and 3<sup>rd</sup> rows and the 1<sup>st</sup> and 2<sup>nd</sup> columns in Table 3 for the correspondences deduced by the KAES program between algebraic symbols and kin terms). Table 3 is based on the algebraic structure and the body of the table lists the predicted kin term products for the kin terms corresponding to the algebra symbols (column heading and row heading) making up the algebraic product. Thus in the algebra, the algebra symbols P and G have product  $PG = PP$  as shown in the intersection of the 4<sup>th</sup> column and the 5<sup>th</sup> row, the algebraic generators P and G (4<sup>th</sup> column and 5<sup>th</sup> row, respectively) are isomorphic to the kin terms *tamai* and *fa'e*, respectively, and the algebra symbol PP corresponds to the kin term *kui* according to the algebraic analysis. Thus the term *kui* in the intersection of the 4<sup>th</sup> row and 5<sup>th</sup> column of the table is the predicted kin term for the kin term product, *tamai* 'father' of *fa'e* 'mother'. From the viewpoint of kin terms, *tamai* 'father' of *fa'e* 'mother' in fact is *kui* 'grandfather,' as predicted. Similar comments apply to all of the other table entries. All of the predicted products are correct, hence the algebraic structure is isomorphic to the complete kin term map for the Tongan consanguineal terms. The generating elements, the sequence for the construction of the algebraic structure and the equations introduced to generate the algebraic structure constitute a "grammar" for the kin term map.

#### 4.3.12 Relationship to the Trobriand Terminology

At this point in the construction we arrive at a bifurcation that accounts for one of the structural differences between the Trobriand and the Tongan terminology. While the Trobriand terminology does not bear directly on the analysis of the Tongan terminology, we include the comparison since the Trobriand terminology figured prominently in the dispute between Edmund Leach and Floyd Lounsbury over whether kin terms are social categorizations and the algebraic analysis shows that the Tongan terminology shares with the Trobriand terminology the same basic structure as occurs with the Trobriand terminology. This section should be read as a prelude to a future, more detailed analysis that works out the structural relations among the classificatory terminologies such as the

---

<sup>26</sup> All of the algebraic calculations, production of structures and testing for isomorphism has been done with the computer program, Kinship Algebra Expert System (KAES) (Read and Fischer 2004).

Tongan terminology. The structural relations will also have historical ramifications for the origin of the Tongan terminology. Here we consider only (and briefly) the structural basis for the differences in the two terminologies.

These two terminologies being with the same structure of ascending and descending terms but then diverge through alternative choices in how the some of the structural features are then developed in the two terminologies (compare the generation of the Trobriand terminology in Read and Behrens 1990 with the generation of the Tongan structure given above). Structurally, there are two, consistent, ways that the labels, MaleSelf and FemaleSelf, can be given semantic labels. One is to give each of them a distinct, sex marked label (e.g. 'brother,' 'sister') and the other is to give both of them a single, neutral label. The former occurs with the Tongan terminology and the latter with the Trobriand terminology. Whereas the Trobriand terminology has a single term, *luta*, used by both a female speaker for a genealogical brother and by a male speaker for a genealogical sister, Tongan has two terms, *tuonga'ane* and *tuofefine*. The Trobriand terminology then diverges further from the Tongan terminology through the introduction of a skewing rule (see Lounsbury 1954).

For our purposes here we note that the close relationship between the structure of the Tongan terminology and the Trobriand terminology in which both terminologies begin with the same structural form. This underscores the inadequacy of Murdock's classification scheme as it is not based on the deep structure level wherein kinship terminology structures are generated but is based instead on the surface level of properties that emerge when terms are mapped onto a genealogical space.

## 5. Tongan Social Life and Kinship Terminology Revisited

Various puzzling issues were raised about TKT in Sections 1-3. We can now attempt to clarify some of them using the results of the algebraic analyses just introduced. We do not claim that all features of a terminology arise from the logic of how a kinship terminology is generated. Rather, the algebraic analysis permits us to determine whether a feature arises from the internal logic of how the structure is generated or whether the feature arises for cultural reasons extrinsic to the logic of how the terminology is generated. This will allow us to distinguish between issues that can be resolved by reference to the logic of how the Tongan terminology is generated as a symbolic structure versus aspects of the terminology (and the kinship system) that do not arise from that logic. The latter are aspects of the terminology where we need to look for cultural interventions in order to account for the presence of those features in the terminology.

Here is a short list of the issues:

1. Siblings are distinguished only according to gender and age: a Tongan female sibling is always higher in rank than her brother; an older same sex sibling is always higher in status than a younger one;
2. The linguistic distinction for *fa'etangata* 'older maternal uncle' and younger *tu'asina* 'younger maternal uncle' is not present in the otherwise symmetrical relationship, *mehekitanga* 'paternal aunts';

3. The general tendency of the terminology at generation 1 down is not to mark for gender (e.g., *tama*, *fakafotu*, *'ilamutu*), but oddly gender is used when reference is made to a male's offspring (i.e., *foha* or *'ofefine*);

4. *Fahu*, where one is *'eiki* 'high' to one's 'mother's brother's children' and is *tu'a* 'low' to one's 'father's sister's children,' is not a kinship term;

5. At a Tongan funeral, in the generation 1 up, the father side is *'eiki* 'high' and the mother side is *tu'a* 'low;' in the generation 1 down, children are *tu'a* if the deceased is male and *'eiki* if the deceased is female;

6. There is a term for 'same sex sibling, *tokoua*, but no corresponding term for 'opposite sex sibling.'

Regarding issue 1, the participation of the two concepts of gender and age in the structural generation of the terminology has become clear after the algebraic analysis. Two structures are independently constructed for male and female members and later joined. We did the construction starting from terms with male attributes, but it was an arbitrary decision and one could start from either a male or a female structure without affecting the results of the process. It is relevant that two gender biased structures need to be independently posited to arrive at an elucidation of the internal logic of the whole TKT. This supports the conclusion we reached that the concept of gender plays a fundamental role in the terminology and the Tongan kinship system.

These conclusions amend the picture of TKT we delineated in our attribute analysis in section 3. The terminology is inherently gendered and aged. The gender neutral terms *kui* 'grandparent,' *motu'a* 'parent,' *tokoua* 'same sex sibling,' *tama* 'child,' and *mokopuna* 'grandchild' while they may still be considered the backbone of TKT, are not its starting point. They are a set of specific terms that perform an important role during the genesis of the terminology. They are the glue that keeps together the two primordial male and female structures shown in Figure 9 to obtain the TKT in its entirety.

Age difference for 'same sex sibling' terms is introduced as a necessary feature in order for there to be consistency with defining reciprocal terms for the sibling terms. Age distinctions are consequently expected to appear and play determinant roles in the final terminology structure through the logic of the terminology. For siblings, we find two gender neutral terms for older and younger by virtue of the logic of the construction and similarly for the child of same sex sibling of parent. For same sex siblings of parents the logic of the construction implies that an older/younger distinction will not be made.

Issues 2 and 3 therefore relate to an application of gender and age distinctions at junctures in the terminology that are not required by its internal logic. Algebraically, the age distinction at the mother's brother level (and not at the father's sister level where there is only one term, *mehekitanga*) realized in the two terms *fa'etangata* 'older MB' and *tu'asina* 'younger MB' is not necessary even though possible. In the same way, the distinction between male and female offspring of a male individual, *foha* and *'ofefine*, (a distinction not present for children of a female where there is only one term, *tama*) is not logically necessary even though possible. This double (gendered and aged) asymmetry clearly points again towards a cultural intervention external to the terminology. Notice, however, that the two asymmetries are obtained by using two basic concepts inherent in the logic of the terminology, thus supporting further our axiomatic choices.

Issue 6 about the centrality of *tokoua* ‘same sex sibling’ in the terminology (also suggested in the attribute analysis in section 3) has been confirmed and clarified by the algebraic analysis. We concluded that *tokoua* is a term that stands outside the logical plane of TKT and is situated in an ontologically prior level. It plays a central role and it functions as the basis from which age but not gender marked sibling terms are constructed. It also provides a contrast for the gender but not age marked sibling terms. This finding highlights the essential participation and central role played by siblinghood in the genesis of TKT and in Tongan kinship relations in general. Significantly, the structural starting point for all the terms is a term for an individual other than self, namely *tokoua*, and from there the terminology is allowed to “grow” and be realized. This finding is congruent with a proposal by one of us regarding the primacy of radiality<sup>27</sup> in the representation of spatial relationships and other domains of Tongan knowledge (Bennardo, 1996, 1999, 2000, 2001, 2002).

The algebraic analysis, however, does not explain why a female sibling is always considered superior to a male sibling. This is a fundamental parameter that regulates several cultural behaviors (e.g., brother/sister avoidance practices) and is at the root of the *fahu* practice as elucidated in issue 4 and 5. No justification by the algebraic logic internal to the terminology was found. We are then confident in asserting that this parameter has been introduced by cultural considerations external to the terminology itself. Why then is a female sibling always superior to her male sibling? The logic of the terminology only points to the fundamental role that gender plays in the genesis of TKT. Given the strict relationship of this phenomenon with the practice of *fahu* (see issues 4 and 5), finding a possible explanation could clarify the justification for *fahu* as well as for the other two asymmetrical uses of gender and age as indicated in issues 2 and 3.

Several authors have pointed out the centrality of the group over the individual in Tongan culture (see Gifford, 1929; Beaglehole and Beaglehole, 1941; Maude, 1971; Korn, 1974, 1978; Marcus, 1977, 1978, 1980; Kaeppler, 1978; Gailey, 1987; van der Grijp, 1993; James, 1995; Small, 1997; Helu, 1999; Evans, 2001; Morton, 2003). A comprehensive treatment of the various basic social units or groups of Tongan social organization and their historical and contemporary dynamics is found in Evans (2001, Chapter 3 for traditional social units and Chapter 5 for contemporary social units). Without going into unnecessary details, we will focus on a couple of important points he makes in his discussion.

All units described, including *ha’a* ‘patrilineage,’ *fa’ahinga/kainga* ‘localized kin group, bilateral kindred, kin people,’ and *famili* ‘members of an individuals’ natal household,’<sup>28</sup> are essentially based on bilateral kinship relationships. *Kainga*, however, “was central to both political and social organization at the local level.” (Evans, 2001:37). Moreover,

---

<sup>27</sup> Thinking radially to locate objects in space implies looking for a fixed point of reference (other than ego) and describing the object to be identified as positioned from/toward that point.

<sup>28</sup> The two terms *famili* and *kainga* often overlap in usage (Evans, 2001:62)

Title and thus political rank generally passed through men; “blood” or social rank was passed through both men and women, and in this the rank of the women was more significant. (Evans, 2001:34)

In “title” one needs to read rights to land use by the titleholder’s group and distribution to the individuals making up the group. A male primogeniture principle is also in place, thus, reiterating the use of age as a constituting and salient part of Tongan social fabric.<sup>29</sup>

Being this the case, then, why elevate one’s sister status to create the *fahu* relationship wherein one’s sister/s and one’s sister/s’ children have open access to one’s property? From the point of view of the individual, this is not a positive outcome. From the point of view of a group, however, these children belong to one’s lineal group and property is with this group after all, specifically and according to Evans the *fa’ahinga* (2001:40). Furthermore, because of the *fahu* relationship, children have open access to their mother’s brother’s property, who belongs to a different group (affinal) than one’s own. One’s group, then, is economically and eventually politically strengthened by this possibility.

Another possible factor involved in establishing female siblings as socially superior to male individuals can be found in the attempt to maintain a balance between these two crucial groups. Since political power was “passed through men,” it was made sure, in a complementary sense, that social power lay with women by making them superior to their siblings (with consequences at every generation level). The algebraic analysis of the terminology clearly indicates that such balancing processes are logically inherent in the genesis of TKT. Specifically, it occurs when the horizontal isomorphism joins the two gendered structures. In addition, the balance created goes beyond the two basic groups of males and females, and creates a new subtle balance between lineal and affinal groups. Then, in the final analysis we find two gender and bilateral groups that are sewn together by the threading role of the *fahu* relationships.

Three factors, keeping property in the lineage, acquiring property from another lineage, and balancing power between gender groups and lineages, all concur in creating the asymmetries of the TKT we have highlighted in issues 2 and 3. It is necessary for a male individual to distinguish between male and female children because inheritance practices demand that, male children inherit title and land. Thus, the TKT includes two gendered terms for children of a male. Primogeniture also participates in the inheritance process, thus it is important to know not only the gender but also the relative age of an individual. This is especially true when exercising one’s privileges with *fahu* individuals. It is really important to know who is the heir to the property if a male wants to take the best advantage of his privileged position as *fahu* towards one’s mother’s brothers. Hence, the TKT distinguishes between older and younger Mbs as a cultural modification of the basic kinship structure

We started this section by indicating a number of issues that our discussion of TKT in sections 1-3 had raised. With the help of the algebraic analysis of TKT we were able to resolve these issues. Issue 6, about the centrality of *tokoua* ‘same sex sibling,’ has been confirmed and further clarified. Issue 1 is not directly resolved by the results of the algebraic analysis, but the same algebraic analysis makes apparent that a resolution is to

---

<sup>29</sup> When no male was present, the title would be passed down to a female child.

be found in a cultural intervention. A centripetal process (inheritance) toward a basic social group (lineage) was suggested as a possible motivator. Inheritance practices were also suggested as possible causes for the asymmetries in TKT indicated in issues 2 and 3. Finally, issues 4 and 5 were found to be related to a basic social stance seen at work in the genesis of the TKT, namely, threading together centrifugal forces inherent in different gender and social groups (e.g., lineages). Both directly and indirectly, then, the algebraic analysis of the TKT provides needed clarifications and insights for the exploration of an unfamiliar social world.

## 6. Conclusion

Loisi, the child whose first birthday celebration was described at the opening of this work, is a teenager now and moved with her family to New Zealand and then Australia six years ago. She is bilingual, fluent in Tongan and English. We don't know about the extent of her biculturalism, but we know for sure that she is competent in using the appropriate Tongan terms for her siblings, her parents and grandparents, her maternal and paternal relatives. Most likely she is capable of understanding who a *fahu* is and who can claim that position in a funeral. In other words, she is a competent TKT user.

Tongans very rarely live in isolation when abroad (Small, 1997; Morton, 2003). They tend to live in communities that attempt to replicate the structure, feel, and pace of a Tongan community. This simple fact will assure Loisi a life full of Tongan events (typically, first birthdays, marriages, and funerals) many of which are constructed around the kinship relationships expressed in the TKT.

Very likely Loisi will not be aware of the generating logic of TKT that the algebraic analyses presented have brought to the fore. She will not be aware of the struggle that her predecessors went through to knead together a by-gender structure from two gendered ones. The ingenious solutions they implemented to obtain gender equality while preserving differences, as well as the skillful way in which group welfare was given priority over individual interests will not be much of her concern. She will very likely need to decide how much of what she unconsciously knows about Tongan kinship can be preserved in the face of a different kinship system she is being exposed to and learning about in the new 'place' in which she is now living. The solutions for her are not yet available, but she stands tall on the shoulders of her ancestors whose exquisite reasoning and logic is partly inscribed in the kinship terminology they left behind.

**References**

- Aoyagi, M. (1966). Kinship Organisation and Behaviour in a Contemporary Tonga Village. *Journal of the Polynesian Society*, 75:141-176.
- Beaglehole, E. and P. Beaglehole. (1941). *Pangai: Village in Tonga*. Wellington, New Zealand: Polynesian Society Memoir, 18.
- Behrens, C. (1984). *Shipibo Ecology and Economy*. Diss. Los Angeles: UCLA.
- Bennardo, G. (2002). Map Drawing in Tonga, Polynesia: Accessing Mental Representations of Space. *Field Methods*, 14, 4:390-417.
- Bennardo, G. (2001). "A Possible Tongan Cultural Model: Radiality." Paper presented at *The 100<sup>th</sup> Annual Meetings of the American Anthropological Association*, Washington, DC. November 28, 2001.
- Bennardo, G. (2000). "Radiality in Tongan Space and Kinship or about the Content of the Interface between two Mental Modules." Paper presented at *The 99<sup>th</sup> Annual Meetings of the American Anthropological Association*, San Francisco, CA. November 19, 2000.
- Bennardo, G. (1999). The Conceptual Content of Tongan Directionals: Mental Representations of Space in Tongan. *Rongorongo Studies*, 9,2:39-61. Auckland, New Zealand: The Institute of Polynesian Languages and Literatures.
- Bennardo, G. (1996). *A Computational Approach to Spatial Cognition: Representing Spatial Relationships in Tongan Language and Culture*. Doctoral dissertation, University of Illinois at Urbana-Champaign, Urbana, Illinois.
- Biersack, A. (1982). Tongan Exchange Structures: Beyond Descent and Alliance. *The Journal of Polynesian Society*, 91, 2:181-212.
- Bott, E. (1982). *Tongan Society at the Time of Captain Cook's Visit*. Wellington: The Polynesian Society
- Byrne, R. W., and A. Whiten. (1997). Machiavellian Intelligence, in *Machiavellian Intelligence II: Extensions and Evaluations*, eds. R. W. Byrne and A. Whiten. Cambridge: Cambridge University Press.
- Buchler, I. and H. Selby. (1968). *Kinship and Social Organization: An Introduction to Theory and Method*. New York: The Macmillan Company.
- Collocott, E. E. V. (1924). Marriage in Tonga. *Journal of the Polynesian Society*, 33:166-184.
- Collocott, E. E. V. (1927). Kava Ceremonial in Tonga. *Journal of the Polynesian Society*, 36:21-47.
- D'andrade, R. (1970). Structure and Syntax in the Semantic Analysis of Kinship Terminologies, in *Cognition: A Multiple View*, ed. P. L. Garvin. New York: Spartan Books. pp. 87-143.
- Dasser, V. (1988). Mapping social concepts in monkeys, in *Machiavellian Intelligence: Social Expertise and the Evolution of Intellect in Monkeys, Apes, and Humans*, eds. R. W. Byrne and A. Whiten. Oxford: Clarendon Press, pp. 85-93.
- Evans, M. (2001). *Persistence of the Gift: Tongan Tradition in Transnational Context*. Toronto: Wilfrid Laurier University Press.
- Gailey, C. W. (1987). *Kinship to Kingship: Gender Hierarchy and State Formation in the Tongan Islands*. Austin, TX: University of Texas Press.
- Gifford, E. W. (1929). *Tongan Society*. Honolulu, Hawai'i: Bernice P. Bishop Museum.

- Helu, F. I. (1999). *Critical Essays: Cultural Perspectives from the South Seas*. Canberra, ACT: The Journal of Pacific History (RSPAS, Australian National University).
- James, K. (1995). Right and Privilege in Tongan Land Tenure. In *Land Custom and Practice in the South Pacific*. Cambridge: Cambridge University Press.
- James, K. (1991). Regeneration in Heaven. *History and Anthropology*, 5, 2:259-267.
- Kaeppler, A. L. (1971). Rank in Tonga. *Ethnology*, 10, 2:174-93.
- Kaeppler, A. L. (1978). *Me'a Faka'eiki: Tongan Funerals in a Changing Society*. In Niel Gunson (Ed.) *The Changing Pacific: Essays in Honour of H. E. Maude*. Oxford: Oxford University Press.
- Keller, J. W. D. and F. K. Lehman (1991). Complex Concepts. *Cognitive Science* 15:271-91.
- Korn, Shumalit R. Decktor. (1974). Tonga Kin Groups: The Noble and the Common View. *Journal of the Polynesian Society*, 83:5-13.
- Korn, Shumalit R. Decktor. (1978). Hunting the Ramage: Kinship and the Organization of Political Authority in Aboriginal Tonga. *Journal of Pacific History*, 13, 1:107-113.
- Kronenfeld, David (1980). Particularistic or Universalistic Analyses of Fanti Kin-Terminology: the Alternative Goals of Terminological Analysis. *Man* (N.S.) 15:151-169.
- Leach, Edmond (1945). Jinglypaw Kinship Terminology: An Experiment in Ethnographic Algebra. *Journal of the Royal Anthropological Institute* 75:59-71.
- Leach, Edmond (1958). Concerning Trobriand Clans and the Kinship Category *Tabu*. In Jack Goody (ed.) *The Development Cycle in Domestic Groups*. Cambridge: Cambridge University Press.
- Leaf, Murray. (1971). The Punjabi Kinship Terminology as a Semantic System. *American Anthropologist* 73:545-554.
- Lehman, F. K. (1993). The Relationship Between Genealogical and Terminological Structure in Kinship Terminologies. *Journal of Quantitative Anthropology*, 4,1:95-122.
- Lehman, F. K. (2000). "Cultural Models (and Schemata) and Generative Knowledge Domains: How Are They Related?" Paper presented at the 99<sup>th</sup> Annual Meetings of the American Anthropological Association, San Francisco, CA. November 19, 2000. See electronic posting at <http://real.anthropology.ac.uk>
- Lehman, F. K. and K. Witz (1974). Prolegomena to a Formal Theory of Kinship. In Paul Ballanoff (ed.) *Genealogical Mathematics*. Pp. 112-134. Paris: Mouton.
- Lehman, F. K. and K. Witz (1979). *A Formal Theory of Kinship: The Transformational Component*. Report #11, Committee on Culture and Cognition. University of Illinois at Urbana-Champaign.
- Leach, E. R. (1958). Concerning Trobriand Clans and the Kinship Category 'Tabu,' in *The Developmental Cycle in Domestic Groups*, ed. J. Goody. Cambridge: Cambridge University Press. pp. 120-145.
- Lounsbury, F. (1965). Another View of the Trobriand Kinship Categories. *Formal Semantic Analysis*, ed. E. A. Hammel. *American Anthropologist*, Special Publication 62((5), Part 2),142-185

- Marcus, G. E. (1977). Succession Disputes and the Position of the Nobility in Modern Tonga. *Oceania*, 47:220-241.
- Marcus, G. E. (1978). Status Rivalry in a Polynesia Steady-State Society. *Ethos*, 6:242-269.
- Marcus, G. E. (1980). *The Nobility and the Chiefly Tradition in the Modern Kingdom of Tonga*. Wellington: The Polynesian Society, Inc.
- Marshall, L. (1976). *The !Kung of Nyae Nyae*. Cambridge: Harvard University Press.
- Martin, J. (1818). *The Natives of the Tongan Islands*. London: John Murray, Albermarle-Street.
- Maude, A. (1971). Tonga: Equality Overtaking Privilege. In *Land Tenure in the Pacific*. Suva: University of the South Pacific.
- Mead, G. H. 1967[1934]. *Mind, Self and Society*. Chicago: The University of Chicago Press.
- Morton, H. (1996). *Becoming Tongan: An Ethnography of Childhood*. Honolulu: University of Hawai'i Press.
- Morton, H. (2003). *Tongan Overseas: Between Two Shores*. Honolulu: University of Hawai'i Press.
- Morton, K. L. (1972). *Kinship, Economics, and Exchange in a Tongan Village*. Ph.D. Dissertation, University of Oregon.
- Read, D. W. (1984) An algebraic account of the American kinship terminology. *Current Anthropology* 25: 417-440.
- Read, D. W. (1997). *Kinship Algebra Expert System: A Software Program for Modeling the Logic of Kinship Terminologies*. Unpublished manuscript. UCLA.
- Read, D. W. (2000). Formal Analysis of Kinship Terminologies and its Relationship to what Constitutes Kinship (Complete Manuscript). *Mathematical Anthropology and Cultural Theory*, 1, 1:1-46. See <http://www.mathematicalanthropology.org/>
- Read, D. W. (2001a). Formal analysis of kinship terminologies and its relationship to what constitutes kinship. [in special issue 'Kinship'] *Anthropological theory*, 1, 2: 239-67.
- Read, D. W. (2001b) What is Kinship? In *The Cultural Analysis of Kinship: The Legacy of David Schneider and Its Implications for Anthropological Relativism*, R. Feinberg and M. Ottenheimer eds. University of Illinois Press, Urbana.
- Read, D. W. and C. A. Behrens (1990). KAES, an Expert System for the Algebraic Analysis of Kinship Terminologies. *Journal of Quantitative Anthropology*, 2:353-93.
- Read, D. W. and M. D. Fischer (2004) Kinship Algebra Expert System (KAES). See <http://kaes.anthrosciences.net/>
- Rivers, W. H. R. (1916). The Father's Sister in Oceania. *Folk-Lore*, 21:42-59.
- Rivers, W. H. R. (1924). *Social Organization*. London: W. J. Perry.
- Rogers, G. (1977). 'The Father's Sister is Black:' A Consideration of Female Rank and Powers in Tonga. *Journal of the Polynesian Society*, 86:157-182.
- Sahlins, M. (1962). *Moala: Culture and Nature on a Fijian Island*. Prentice-Hall, Englewood Cliffs.
- Schneider, David (1984) *A Critique of the Study of Kinship*. Ann Arbor: University of Michigan Press.

- Shapiro, Warren (1982). The Place of Cognitive Extensionism in the History of Anthropological Thought. *Journal of the Polynesian Society*, 91:257-297.
- Small, C. (1997). *Voyages: From Tongan Villages to American Suburbs*. Ithaca: Cornell University Press
- Tupouniua, P. (1977). *A Polynesian Village: The Process of Change* . Suva, Fiji: South Pacific Social Sciences Association.
- van der Grijp, P. (1993). *Islanders of the South*. Leiden: KITLV Press.